



PREMIUM-WERKZEUGE



PREMIUM TOOLS



www.kstools.com

HAMMER & CHISELS

SOFT HEAD HAMMER

Brass hammer

- Full brass execution
- Protective material

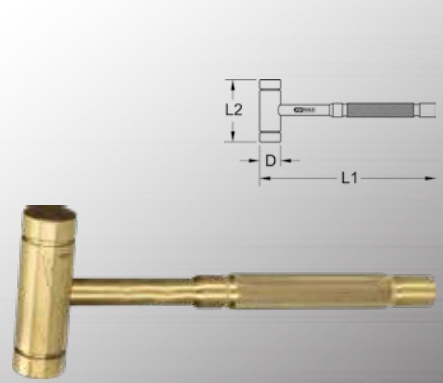

	g	D mm	L1 mm	L2 mm	Handle number	g	€
140.2081	800	26,0	230,0	83,0	140.5301 140.5401	230	83,90
140.2082	1400	31,0	260,0	100,0	140.5304 140.5404	450	122,90

Plastic hammer

- With transparent head made from impact resistant cellulose acetate
- Impact heads are exchangeable (screw thread)
- With hickory handle
- Ideal for hammering out and gentle sheet metal working

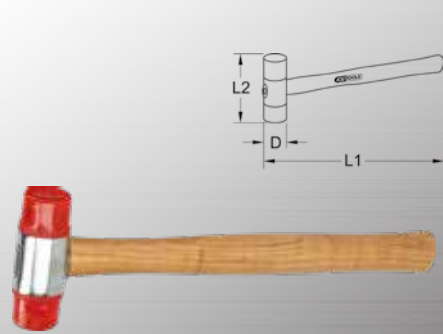

	g	D mm	L1 mm	L2 mm	Handle number	g	€
140.5201	200	28,0	260,0	82,0	140.5301 140.5401	210	11,90
140.5202	340	35,0	300,0	95,0	140.5304 140.5404	350	10,90



Nylon hammer

- With impact heads made out of impact resistant nylon
- shatterproof, break and wear-resistant
- With hickory handle
- Ideal for hammering out and gentle sheet metal working

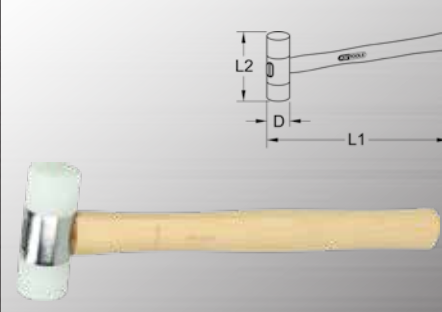

	g	D mm	L1 mm	L2 mm	Handle number	g	€
140.5211	200	28,0	260,0	82,0	140.5301 140.5401	230	11,90
140.5212	340	35,0	300,0	95,0	140.5304 140.5404	450	12,90

Rubber hammer

- DIN 5128
- With hickory handle
- Hammer head made out of hard rubber

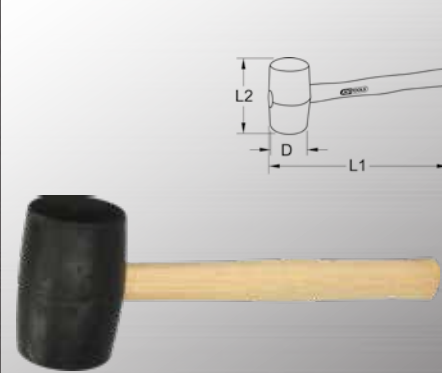

	g	D mm	L1 mm	L2 mm	Handle number	g	€
140.5221	300	45,0	300,0	80,0	140.5304 140.5404	340	9,90
140.5222	500	58,0	310,0	95,0	140.5305 140.5405	560	9,90
140.5223	700	63,0	345,0	112,0	140.5306 140.5405	780	10,90

Rubber hammer

- DIN 5128
- With tapered hickory inserted handle
- Hammer head made out of hard rubber

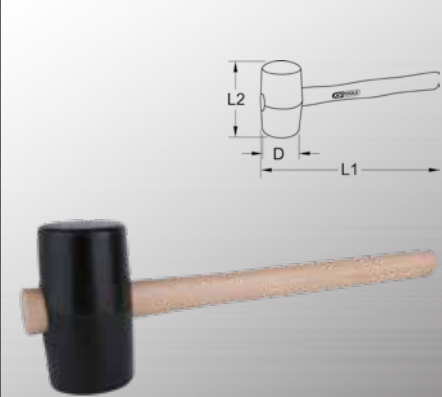

	g	D mm	L1 mm	L2 mm	g	€
140.1230	425	60,0	340,0	110,0	525	8,90

Rubber hammer

- DIN 5128
- With fibreglass handle
- Hammer head made out of hard rubber

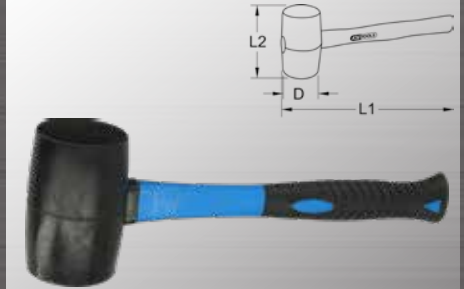

	g	D mm	L1 mm	L2 mm	g	€
140.1237	500	56,0	325,0	100,0	520	13,90

Rubber hammer

- DIN 5128
- With tapered hickory inserted handle
- Hammer head made out of hard rubber
- With white rubber head

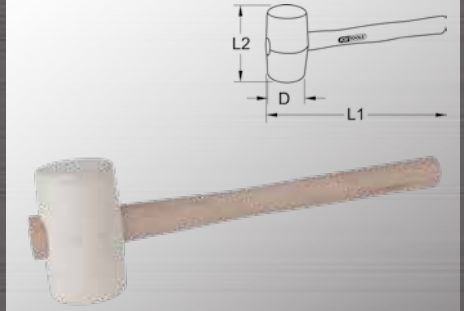

	g	D mm	L1 mm	L2 mm	g	€
140.1234	270	55,0	300,0	115,0	300	12,90
140.1235	500	60,0	340,0	115,0	595	12,90
140.1236	735	65,0	380,0	130,0	855	18,90

Recoil free soft faced hammer

- With hickory handle
- Shock absorbing effect through steel shot in the head
- Up to 100% higher impact effect than normal Soft head hammers
- Shatterproof and wear resistant
- Polyamid heads interchangeable
- For safer working with less recoil

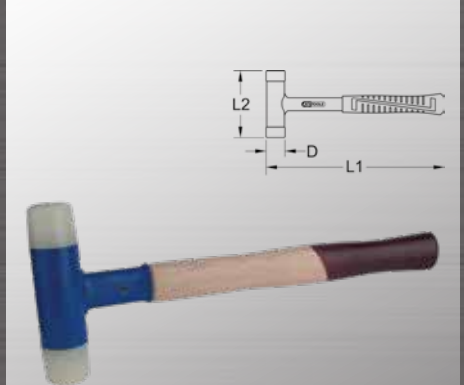

	g	D mm	L1 mm	L2 mm	g	€
140.1215	350	35,0	330,0	120,0	480	63,90

Recoil free soft faced hammer

- With steel tube handle and plastic handle
- Shock absorbing effect through steel shot in the head
- Up to 100% higher impact effect than normal Soft head hammers
- Shatterproof and wear resistant
- Polyamid heads interchangeable
- For safer working with less recoil

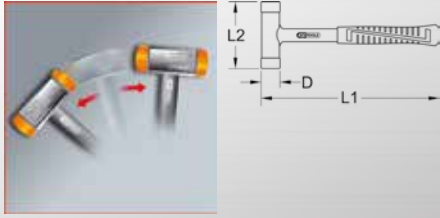

	g	D mm	L1 mm	L2 mm	head spare	g	€
140.5270	360	25,0	290,0	105,0	140.5280	360	31,90
140.5271	480	30,0	290,0	110,0	140.5281	500	36,90
140.5272	590	35,0	295,0	110,0	140.5282	590	36,90
140.5273	850	40,0	300,0	120,0	140.5283	650	42,90
140.5274	990	45,0	305,0	125,0	140.5284	950	42,90
140.5275	1110	50,0	310,0	125,0	140.5285	1080	50,90
140.5277	1670	60,0	360,0	140,0	140.5287	1420	61,90

Recoil free soft faced hammer

- Polyurethane fiberglass composite
- Serrated surface for secure grip
- Free of sparks due to rubber cover
- Special absorbing effect through steel shot in the hammer head
- Substantially higher blow effect than in conventional hammering
- For safer working with less recoil



	g	D mm	L1 mm	L2 mm	g	€
140.5252	500	46,0	300,0	100,0	690	22,90
140.5254	570	46,0	300,0	100,0	750	28,90
140.5255	600	50,0	325,0	100,0	860	34,90
140.5256	620	54,0	340,0	100,0	900	34,90
140.5257	1050	60,0	350,0	126,0	1450	41,90
140.5258	1250	70,0	370,0	135,0	1800	53,90

Recoil free soft faced hammer, extra large

- Polyurethane fiberglass composite
- Rubber handle for better grip
- Special absorbing effect through steel shot in the hammer head
- Substantially higher blow effect than in conventional hammering
- For safer working with less recoil



	g	D mm	L1 mm	L2 mm	g	€
140.5259	5500	105,0	890,0	180,0	5,76	81,90

INSULATED SOFT-HEAD HAMMERS

Soft-face hammer with protective insulation

- Insulated to IEC 60900
- Shock absorbing effect through steel shot in the head
- Shatterproof and wear resistant
- Polyamid heads interchangeable
- For safer working with less recoil

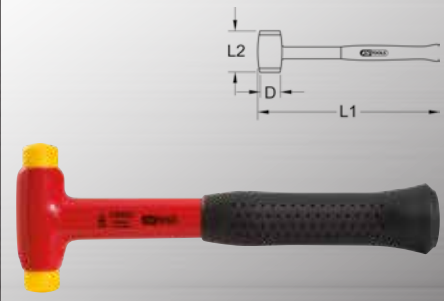

	D mm	L1 mm	L2 mm	head spare	⚡	g	€
117.1126	25,0	300,0	105,0	117.1128	1000V	560	124,90
117.1127	35,0	310,0	115,0	117.1129	1000V	790	135,90

Plastic hammer with protective insulation

- Insulated to IEC 60900
- Made from plastic
- Without metal parts

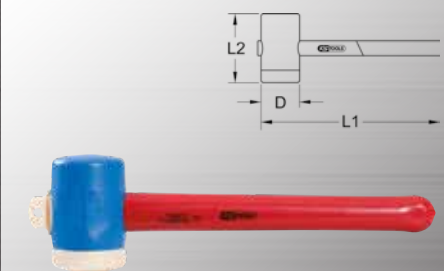

	D mm	L1 mm	L2 mm	⚡	g	€
117.1131	55,0	300,0	82,0	1000V	325	39,90

FITTERS HAMMER

Pin hammer

- With hickory handle
- Additional head security
- Extremely durable

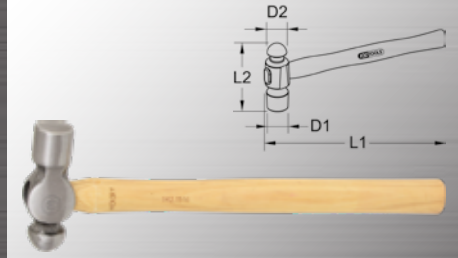

	g	D1 mm	D2 mm	L1 mm	L2 mm	Handle number	g	€	
142.1508	225	20,0	20,0	290,0	80,0	142.1510	140.5403	300	7,90
142.1512	340	28,0	25,0	310,0	91,0	142.1520	140.5403	420	8,90
142.1516	450	30,0	27,0	350,0	102,0	142.1530	140.5405	550	9,90
142.1524	680	38,0	32,0	365,0	116,0	142.1540	140.5405	800	12,90
142.1532	900	40,0	35,0	380,0	130,0	142.1550	140.5405	1100	14,90

Fitters hammer, French form

- With hickory handle
- Forged execution
- Impact area surfaces inductively hardened
- Head and edge areas polished ground
- Rounded edges
- Head coating made from structured powder baked lacquer
- Hammer head made out of high quality special steel

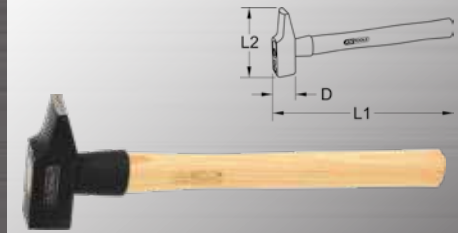

	g	D mm	L1 mm	L2 mm	Handle number	g	€	
142.1030	250	25,0	300,0	81,5	142.5301	140.5401	365	8,90
142.1032	300	28,0	282,0	87,0	142.5302	140.5402	390	9,90
142.1050	400	32,0	320,0	92,0	142.5302	140.5402	525	9,90
142.1033	500	32,0	305,0	100,0	142.5325	140.5403	560	11,90
142.1080	800	40,0	350,0	110,0	142.5303	140.5403	1055	13,90
142.1100	1000	42,0	360,0	120,0	142.5303	140.5403	1140	13,90
142.1150	1500	50,0	380,0	138,0	142.5304	140.5404	1957	16,90
142.1034	2000	57,0	385,0	140,0	142.5304	140.5404	2150	15,90
142.1250	2500	60,0	380,0	150,0	142.5304	140.5404	2730	19,90

Fitters hammer, French form

- With fiberglass handle
- Forged execution
- Impact area surfaces inductively hardened
- Head and edge areas polished ground
- Rounded edges
- Head coating made from structured powder baked lacquer
- Hammer head made out of high quality special steel



	g	D mm	L1 mm	L2 mm	g	€
142.1031	250	25,0	290,0	81,5	415	9,90
142.1051	400	32,0	310,0	92,0	575	10,90
142.1081	800	40,0	338,0	110,0	1160	13,90
142.1101	1000	42,0	340,0	117,0	1270	14,90
142.1151	1500	50,0	405,0	138,0	2140	16,90

Fitters hammer

- DIN 1041
- With hickory handle
- Forged execution
- Impact area surfaces inductively hardened
- Head and edge areas polished ground
- Rounded edges
- Head coating made from structured powder baked lacquer
- Hammer head made out of high quality special steel

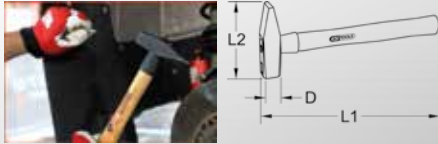

	g	D mm	L1 mm	L2 mm	Handle number	g	€
142.1310	100	15,0	260,0	82,0	142.5305 140.5405	180	11,90
142.1320	200	19,0	280,0	95,0	142.5306 140.5405	283	10,90
142.1330	300	23,0	300,0	105,0	142.5307 140.5405	350	14,90
142.1315	400	25,0	320,0	112,0	142.5307 140.5405	530	20,90
142.1350	500	27,0	320,0	118,0	142.5308 -	590	14,90
142.1316	600	29,0	330,0	122,0	142.5308 -	750	12,90
142.1380	800	33,0	350,0	130,0	142.5309 -	920	11,90
142.1400	1000	36,0	360,0	135,0	142.5310 -	1268	13,90
142.1318	1500	42,0	380,0	145,0	142.5318 140.5408	1750	18,90
142.1319	2000	47,0	400,0	155,0	142.5318 140.5408	2250	19,90

Fitters hammer

- DIN 1041
- With fibreglass handle
- Forged execution
- Impact area surfaces inductively hardened
- Head and edge areas polished ground
- Rounded edges
- Head coating made from structured powder baked lacquer
- Hammer head made out of high quality special steel

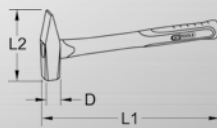

	g	D mm	L1 mm	L2 mm	g	€
142.1311	100	15,0	260,0	82,0	180	12,90
142.1321	200	19,0	280,0	95,0	280	7,90
142.1331	300	23,0	300,0	105,0	500	10,90
142.1402	400	25,0	320,0	112,0	530	9,90
142.1351	500	27,0	320,0	118,0	590	10,90
142.1403	600	29,0	330,0	122,0	750	10,90
142.1381	800	33,0	350,0	130,0	920	13,90
142.1401	1000	36,0	360,0	135,0	1325	15,90
142.1404	1500	42,0	380,0	145,0	1880	16,90
142.1405	2000	47,0	400,0	155,0	2100	18,90

Fitters hammer

- DIN 1041
- With steel tube handle
- Forged execution
- Impact area surfaces inductively hardened
- Head and edge areas polished ground
- Rounded edges
- Head coating made from structured powder baked lacquer
- Hammer head made out of high quality special steel

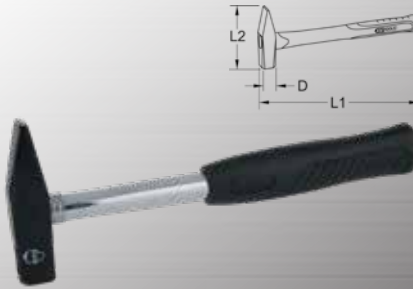

	g	D mm	L1 mm	L2 mm	g	€
142.1221	350	20,0	300,0	100,0	580	30,90

CLAW HAMMERS

Claw hammer, French form

- With lacquered hickory handle
- Forged execution
- Impact area surfaces inductively hardened
- Head and edge areas polished ground
- Rounded edges
- Head coating made from structured powder baked lacquer
- Hammer head made out of high quality special steel



	g	D mm	L1 mm	L2 mm	Handle number	g	€
142.2020	200	20,0	270,0	92,0	142.5311 140.5401	300	7,90
142.2045	500	30,0	310,0	121,0	142.5313 140.5402	600	10,90

Claw hammer, French form

- With fibreglass handle
- Forged execution
- Impact area surfaces inductively hardened
- Head and edge areas polished ground
- Rounded edges
- Head coating made from structured powder baked lacquer
- Hammer head made out of high quality special steel



	g	D mm	L1 mm	L2 mm	g	€
142.2021	200	20,0	285,0	92,0	270	12,90
142.2033	250	22,0	290,0	107,0	320	9,90
142.2046	500	30,0	328,0	121,0	600	10,90

ELECTRICIANS HAMMER

Electricians hammer, French form

- With lacquered hickory handle
- Forged execution
- Impact area surfaces inductively hardened
- Head and edge areas polished ground
- Rounded edges
- Head coating made from structured powder baked lacquer
- Hammer head made out of high quality special steel

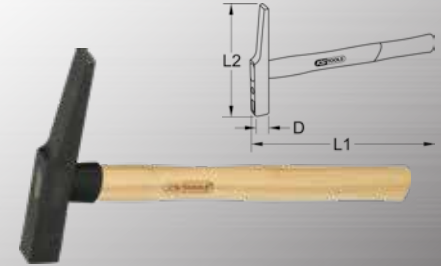

	g	D mm	L1 mm	L2 mm	Handle number	g	€
142.4020	200	18,0	260,0	128,0	142.5314 140.5401	260	7,90

Electricians hammer, French form

- With fibreglass handle
- Forged execution
- Impact area surfaces inductively hardened
- Head and edge areas polished ground
- Rounded edges
- Head coating made from structured powder baked lacquer
- Hammer head made out of high quality special steel



	g	D mm	L1 mm	L2 mm	g	€
142.4030	200	18,0	285,0	126,0	250	7,90

SCABBLING PICK

Scabbling pick

- With steel tube handle and plastic handle
- Forged execution
- Impact area surfaces inductively hardened
- Hammer head made out of high quality special steel
- Head coating made from structured powder baked lacquer
- Pane with nail puller
- With nail holder

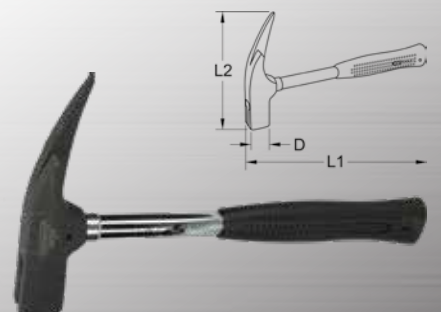

	g	D mm	L1 mm	L2 mm	g	€
140.2001	600	30,0	320,0	170,0	835	12,90

Scabbling pick, magnetic

- With steel tube handle and plastic handle
- Forged execution
- Impact area surfaces inductively hardened
- Hammer head made out of high quality special steel
- Head coating made from structured powder baked lacquer
- Pane with nail puller
- With nail holder

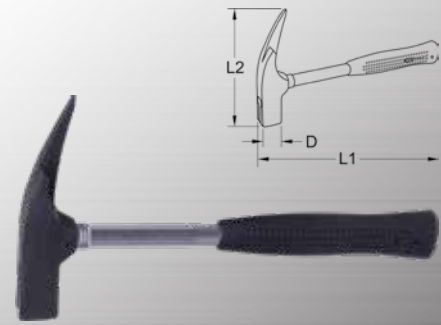

	g	D mm	L1 mm	L2 mm	g	€
140.2002	600	30,0	320,0	170,0	900	9,90

CLAW HAMMER

Claw hammer

- With tapered hickory inserted handle
- Forged execution
- Impact area surfaces inductively hardened
- Head and edge areas polished ground
- Rounded edges
- Hammer head made out of high quality special steel
- Head coating made from structured powder baked lacquer
- Pane with nail puller
- With nail holder



	g	D mm	L1 mm	L2 mm	L3 mm	Handle number	g	€
142.2008	700	30,0	370,0	172,0	48,0	140.5315	860	12,90

Claw hammer

- With tapered fiberglass handle
- Forged execution
- Impact area surfaces inductively hardened
- Head and edge areas polished ground
- Rounded edges
- Hammer head made out of high quality special steel
- Head coating made from structured powder baked lacquer
- Pane with nail puller
- With nail holder



	g	D mm	L1 mm	L2 mm	L3 mm	Handle number	g	€
142.2010	700	28,0	370,0	172,0	48,0	142.5315	920	17,90



BRICK HAMMER

Brick hammer, Rhenish form

- With steel tube handle and plastic handle
- Forged execution
- Impact area surfaces inductively hardened
- Hammer head made out of high quality special steel
- Head coating made from structured powder baked lacquer
- Extremely strong and robust

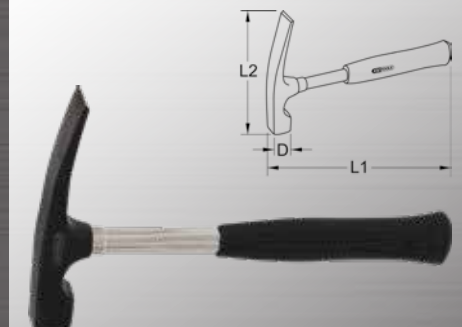

	g	D mm	L1 mm	L2 mm	g	€
140.2030	500	25,0	270,0	178,0	800	10,90

Claw hammer American form

- Steel tube handle and plastic handle
- Forged execution
- Impact area surfaces inductively hardened
- Head and edge areas polished ground
- Rounded edges
- Hammer head made out of high quality special steel
- Head coating made from structured powder baked lacquer
- Pane with nail puller

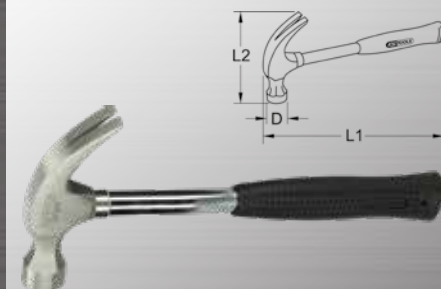

	g	D mm	L1 mm	L2 mm	g	€
140.2006	600	30,0	320,0	133,0	850	9,90

Brick hammer, Berlin form

- With steel tube handle and plastic handle
- Forged execution
- Impact area surfaces inductively hardened
- Hammer head with nail puller
- Head coating made from structured powder baked lacquer
- Hammer head made out of high quality special steel

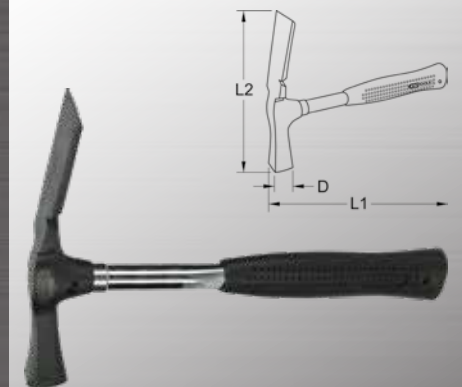

	g	D mm	L1 mm	L2 mm	g	€
140.2003	600	27,0	270,0	203,0	940	10,90

Brick hammer, American form

- With hickory handle
- Forged execution
- Impact area surfaces inductively hardened
- Hammer head made out of high quality special steel
- Head coating made from structured powder baked lacquer
- Extremely strong and robust



	g	D mm	L1 mm	L2 mm	g	€
142.1417	600	27,0	320,0	163,0	800	10,90

Concrete shell hammer, magnetic

- With steel tube handle and plastic handle
- Forged execution
- for scraping off concrete residues
- Impact area surfaces inductively hardened
- Hammer head made out of high quality special steel
- Head coating made from structured powder baked lacquer
- Pane with nail puller
- With nail holder

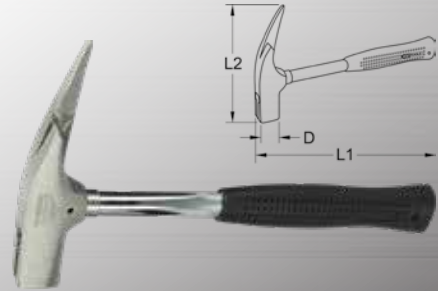

	g	D mm	L1 mm	L2 mm	kg	€
142.1411	600	28,0	310,0	170,0	0,83	10,90

CLUB HAMMER

Club hammer

- DIN 6475
- With lacquered hickory handle
- Forged execution
- Impact area surfaces inductively hardened
- Surfaces polished ground
- Rounded edges
- Head coating made from structured powder baked lacquer
- Hammer head made out of high quality special steel

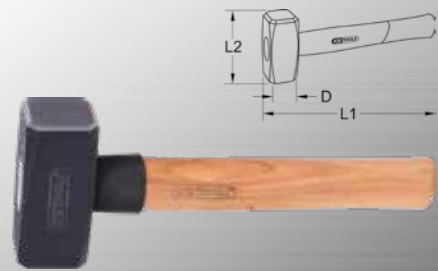

	g	D mm	L1 mm	L2 mm	Handle number	kg	€
142.5100	1000	40,0	260,0	95,0	142.5316 140.5405	1,10	12,90
142.5125	1250	43,0	260,0	100,0	142.5317 140.5405	1,36	13,90
142.5150	1500	45,0	280,0	110,0	142.5318	-	14,90
142.5111	2000	50,0	300,0	120,0	142.5318	-	16,90

Club hammer

- DIN 6475
- With fiberglass handle
- Forged execution
- Impact area surfaces inductively hardened
- Surfaces polished ground
- Rounded edges
- Head coating made from structured powder baked lacquer
- Hammer head made out of high quality special steel



	g	D mm	L1 mm	L2 mm	kg	€
142.5101	1000	40,0	260,0	95,0	1,13	12,90
142.5126	1250	43,0	260,0	100,0	1,36	13,90
142.5151	1500	45,0	280,0	110,0	1,65	19,90

Club hammer

- DIN 6475
- With steel tube handle and plastic handle
- Forged execution
- Impact area surfaces inductively hardened
- Surfaces polished ground
- Rounded edges
- Head coating made from structured powder baked lacquer
- Hammer head made out of high quality special steel

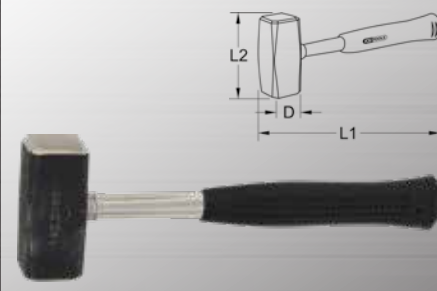

	g	D mm	L1 mm	L2 mm	kg	€
142.5165	1000	40,0	260,0	95,0	1,18	12,90
142.5166	1250	43,0	260,0	100,0	1,43	25,90

Rubber cap for club hammer

- Rubber cap for club hammer to DIN 6475

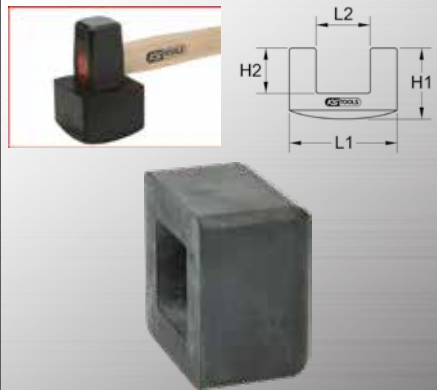

	H1 mm	H2 mm	L1 mm	L2 mm	g	€
140.2075	55,0	27,0	72,0	40,0	400	3,90
140.2076	55,0	29,0	72,0	42,0	400	3,90
140.2077	55,0	33,0	72,0	44,0	400	3,90

SLEDGE HAMMER

Sledge hammer

- Forged execution
- With tapered hickory inserted handle
- Impact area surfaces inductively hardened
- Surfaces polished ground
- Rounded edges
- Head coating made from structured powder baked lacquer
- Hammer head made out of high quality special steel

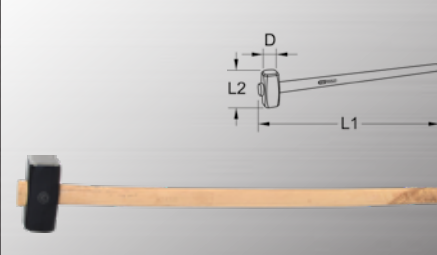

	g	D mm	L1 mm	L2 mm	Handle number	kg	€
142.6300	3000	58,0	900,0	138,0	140.5330	3,50	36,90
142.6400	4000	64,0	900,0	148,0	140.5330	4,44	41,90
142.6500	5000	70,0	900,0	158,0	140.5340	5,44	39,90

Sledge hammer

- With tapered fiberglass handle
- Forged execution
- Impact area surfaces inductively hardened
- Surfaces polished ground
- Rounded edges
- Head coating made from structured powder baked lacquer
- Hammer head made out of high quality special steel

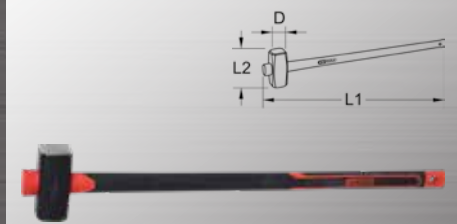

	g	D mm	L1 mm	L2 mm	Handle number	kg	€
142.6301	3000	58,0	900,0	138,0	142.5323	3,80	36,90
142.6401	4000	64,0	900,0	148,0	142.5323	4,80	39,90
142.6501	5000	70,0	900,0	158,0	142.5332	5,80	44,90



Sledge hammer

- DIN 1042
- With ash handle
- Forged execution
- Impact area surfaces inductively hardened
- Surfaces polished ground
- Rounded edges
- Head coating made from structured powder baked lacquer
- Hammer head made out of high quality special steel

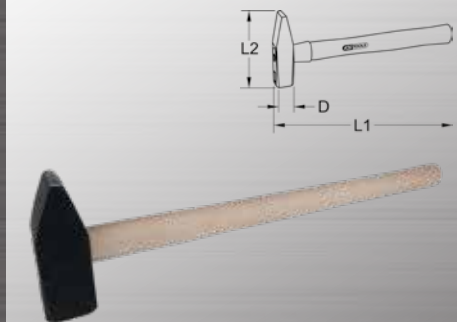

	g	D mm	L1 mm	L2 mm	kg	€
142.1223	3000	54,0	600,0	162,0	3,30	58,90
142.1226	5000	70,0	795,0	180,0	5,64	63,90
142.1227	8000	80,0	895,0	220,0	8,80	104,90
142.1228	10000	85,0	900,0	225,0	10,72	119,90

Sledge hammer

- With fibreglass handle
- Forged execution
- Impact area surfaces inductively hardened
- Surfaces polished ground
- Rounded edges
- Head coating made from structured powder baked lacquer
- Hammer head made out of high quality special steel

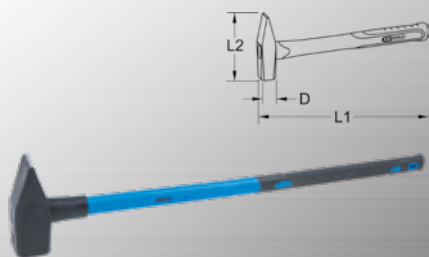

	g	D mm	L1 mm	L2 mm	kg	€
142.1210	5000	70,0	880,0	180,0	6,00	132,90

BOLSTER CHISEL

Bolster chisel

- Flat oval form
- Quenched and tempered
- Blade can be resharpened
- Shaft gold lacquer
- Carbon manganese silicon steel

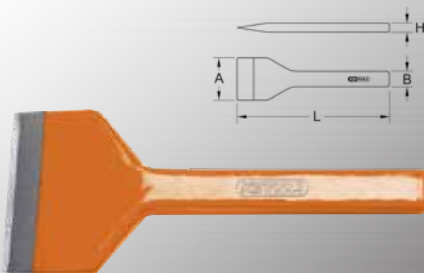

	L mm	A mm	H mm	B mm	g	€
162.0431	200,0	60,0	15,0	18,0	500	41,90
162.0432	200,0	80,0	15,0	20,0	600	49,90
162.0433	220,0	100,0	18,0	22,0	750	57,90
162.0434	220,0	120,0	18,0	22,0	900	70,90

CHIPPING HAMMERS

Chipping hammer

- DIN 5133
- With steel tube handle

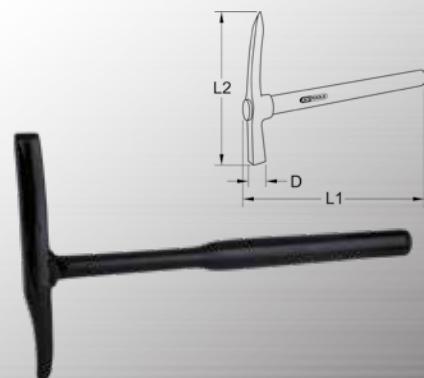

	D mm	L1 mm	L2 mm	kg	€
140.1220	15,0	295,0	155,0	360	17,90



AXES AND HATCHETS

Wood axe

- DIN 5131
- With cambered hickory handle
- Handle with round double fixed wedges
- Forged execution
- Blade polished ground
- Head coating made from structured powder baked lacquer
- Axe head made out of high quality special steel

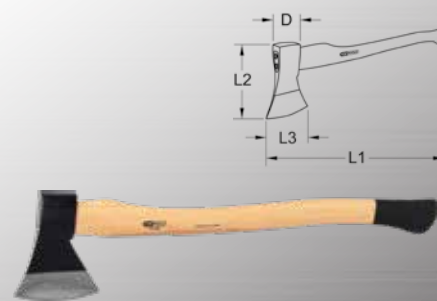

	g	D mm	L1 mm	L2 mm	L3 mm	Handle number	kg	€	
140.2066	1250	60,0	700,0	185,0	130,0	140.2069	140.5405	1,80	30,90

Axe

- DIN 7287
- Forged execution
- Blade polished ground
- Head coating made from structured powder baked lacquer
- Axe head made out of high quality special steel
- With fibreglass handle

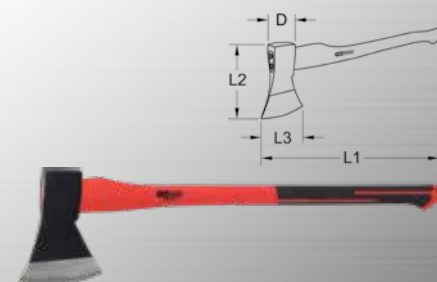

	g	D mm	L1 mm	L2 mm	L3 mm	kg	€
140.1213	1800	60,0	690,0	185,0	137,0	2,71	38,90

Hand axe

- DIN 5131
- With cambered hickory handle
- Handle with round double fixed wedges
- Forged execution
- Blade polished ground
- Head coating made from structured powder baked lacquer
- Axe head made out of high quality special steel



	g	D mm	L1 mm	L2 mm	L3 mm	Handle number	kg	€	
140.2062	600	40,0	350,0	15,0	105,0	140.2067	140.5403	800	13,90
140.2063	800	45,0	380,0	17,0	115,0	140.2068	140.5405	1040	15,90

Hand axe

- DIN 5131
- With fiberglass handle
- Forged execution
- Blade polished ground
- Head coating made from structured powder baked lacquer
- Axe head made out of high quality special steel

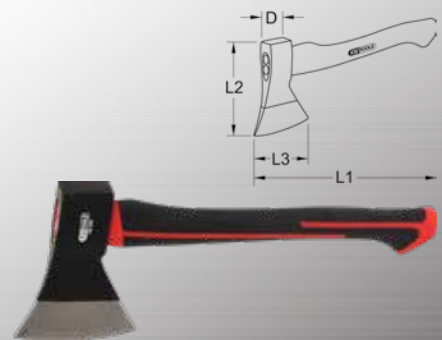

	g	D mm	L1 mm	L2 mm	L3 mm	kg	€
140.1239	800	40,0	350,0	150,0	110,0	1232	17,90

Plasterers axe

- With steel tube handle and plastic handle
- Forged execution
- Impact area surfaces inductively hardened
- Blade polished ground, serrated hammer head
- Hammer head with nail puller
- Head coating made from structured powder baked lacquer
- Hammer head made out of high quality special steel



	g	D mm	L1 mm	L2 mm	L3 mm	kg	€
140.2004	600	27,0	330,0	180,0	70,0	900	9,90

Plasterers axe with fiberglass handle

- With tapered fiberglass handle
- Forged execution
- Impact area surfaces inductively hardened
- Blade polished ground, serrated hammer head
- Hammer head with nail puller
- Head coating made from structured powder baked lacquer
- Hammer head made out of high quality special steel



	g	D mm	L1 mm	L2 mm	L3 mm	kg	€
142.2013	600	28,0	310,0	180,0	22,0	860	12,90

PANEL BEATING HAMMERS

Bodywork serrated hammer

- For hammering out the bodywork area
- High-quality design
- Work area coarse
- Special tool steel
- With ash handle



	Length mm	head length mm	square dim. mm	kg	€
140.2204	325,0	60,0	30 x 45 mm	330	39,90

Bodywork standard hammer, slightly curved

- For hammering out the bodywork area
- High-quality design
- Work area ground and lightly arched
- Special tool steel
- With ash handle



	Length mm	head length mm	square dim. mm	kg	€
140.2209	325,0	60,0	30 x 45 mm	330	36,90

Bodywork standard hammer, sharply curved

- For hammering out the bodywork area
- High-quality design
- Work area ground and strongly arched
- Special tool steel
- With ash handle



	Length mm	head length mm	square dim. mm	kg	€
140.2319	325,0	60,0	30 x 45 mm	360	35,90

Bodywork dinging hammer set

- For hammering out the car body
- High-quality design
- Optimum composition of rough and curved faces
- Work areas ground
- Special tool steel
- In durable plastic storage case
- With ash handle



	kg	€	
140.2200	3 pcs	1,02	118,90

consists of:

	kg	
140.2204	Bodywork serrated hammer, 30x45mm	330
140.2209	Bodywork standard hammer, slightly curved, 30x45mm	330
140.2319	Bodywork standard hammer, sharply curved, 30x45mm	360

Panel beaters hammer

- With hickory handle
- Forged execution
- Impact area surfaces inductively hardened
- Head and edge areas polished ground
- Rounded edges
- Head coating made from structured powder baked lacquer
- Hammer head made out of high quality special steel

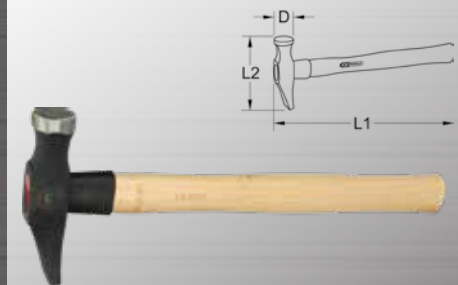

	g	D mm	L1 mm	L2 mm	Handle number	kg	€
140.4003	400	30,0	310,0	118,0	140.5304 140.5404	560	11,90

Panel beater's serrated hammer, round/tip

- For reworking repaired areas, distortion-free
- Stresses are removed from the plate using a special profile in the impact area
- For tightening with a round, rough serrated head
- Fine face curved for accurate hammering out
- Special tool steel
- With ash handle



	Length mm	head length mm	Ø round side mm	Tip width mm	kg	€
140.2109	280,0	120,0	40,0	20,0	460	49,90

Wing dinging hammer

- Ideal for hammering out the wings
- Extra heavy execution
- Fine face curved for accurate hammering out
- Safe and easy use
- Work areas ground
- With hickory handle
- Special tool steel



	Length mm	head length mm	square dim. mm	Tip width mm	kg	€
140.2461	380,0	220	30 x 38 mm	35	1,31	72,90

Panel beaters pick hammer straight head, round/pointed

- Planishing hammer with a round, slightly domed face
- Fine conical face for accurate hammering out
- Work areas ground
- Special tool steel
- With ash handle



	Length mm	head length mm	Ø round side mm	g	€
140.2137	325,0	140,0	40,0	460	28,90



Aluminium bodywork pick hammer curved head, round/ tip

- For hammering out aluminium car body panels
- Planishing hammer with a round, slightly domed face
- Fine conical face for accurate hammering out
- Polished surface
- Aluminium
- With ash handle



	Length mm	head length mm	Ø round side mm	g	€
700.1489	300,0	140,0	40,0	110	60,90

Panel beaters pick hammer straight head, flat/pointed

- Planishing hammer with a round, slightly domed face
- Fine face curved for accurate hammering out
- Work areas ground
- Special tool steel
- With ash handle



	Length mm	head length mm	Ø round side mm	Tip width mm	g	€
140.2131	325,0	140,0	40,0	19,0	460	28,90

Panel beaters hammer, small round/square

- Simple hammer with a flat, angular face and a round, slightly arched face
- Work areas ground
- Special tool steel
- With ash handle



	Length mm	head length mm	Ø round side mm	square dim. mm	g	€
140.2138	325,0	100,0	30,0	28 x 28 mm	390	28,90

Aluminium bodywork flat pick hammer curved head, round/flat tip

- For hammering out aluminium car body panels
- Planishing hammer with a round, slightly domed face
- Fine face for accurate hammering out
- Polished surface
- Aluminium
- With ash handle



	Length mm	head length mm	Ø round side mm	Tip width mm	g	€
700.1490	300,0	140,0	40,0	20,0	140	43,90

Aluminium bodywork standard hammer curved head, round/square

- For hammering out aluminium car body panels
- Simple hammer with a flat, angular face and a round, slightly arched face
- Polished surface
- Aluminium
- With ash handle



	Length mm	head length mm	Ø round side mm	square dim. mm	g	€
700.1491	300,0	100,0	40,0	38 x 38 mm	148	43,90

Panel beaters serrated hammer, round/square

- For forming with a square, finely serrated face
- For stretching with a round, slightly domed face
- Round work surfaces ground
- Special tool steel
- With ash handle



	Length mm	head length mm	Ø round side mm	square dim. mm	g	€
140.2132	325,0	100,0	40,0	38 x 38 mm	490	33,90

Panel beaters pick hammer straight head, round/flat point

- Planishing hammer with a round, slightly domed face
- Fine face for accurate hammering out
- Work areas ground
- Special tool steel
- With ash handle



	Length mm	head length mm	Ø round side mm	Tip width mm	g	€
140.2136	325,0	140,0	40,0	19,0	460	29,90

Panel beaters hammer, round/square

- Bumping hammer with strong arched faces
- Work areas ground
- Special tool steel
- With ash handle



	Length mm	head length mm	Ø round side mm	square dim. mm	g	€
140.2130	325,0	105,0	30,0	26 x 26 mm	390	29,90

Panel beaters hammer rounded head, small round/square

- Simple hammer with a flat, angular face and a round, slightly arched face
- Work areas ground
- Special tool steel
- With ash handle



	Length mm	head length mm	Ø round side mm	square dim. mm	g	€
140.2135	325,0	100,0	30,0	27 x 27 mm	390	32,90

Panel beaters standard hammer, large round/square

- Planishing hammer with a square and round, flat face
- Work areas ground
- Special tool steel
- With ash handle



	Length mm	head length mm	Ø round side mm	square dia. mm	g	€
140.2133	325,0	100,0	40,0	39 x 39 mm	420	31,90

Panel beaters standard hammer curved head, large round/square

- Simple hammer with a flat, angular face and a round, slightly arched face
- Work areas ground
- Special tool steel
- With ash handle



	Length mm	head length mm	Ø round side mm	square dia. mm	g	€
140.2134	325,0	100,0	40,0	38 x 38 mm	490	33,90

Panel beaters serrated hammer fine, round/square

- For forming with an square, rough serrated face
- For stretching with a round, slightly domed face
- Round work surfaces ground
- Special tool steel
- With ash handle



	Length mm	head length mm	Ø round side mm	square dia. mm	g	€
140.2139	325,0	100,0	40,0	38 x 38 mm	490	33,90

Aluminium hammer

- With hickory handle
- Aluminium head
- Protective material



	g	Ø mm	Length mm	head length mm	Handle number	g	€
140.2121	280	30,0	310,0	145,0	140.2122 140.2123	380	26,90

REPLACEMENT HANDLES

Replacement handles, hickory

- Without wedge



	L mm	Handle form	Handle style	g	€
140.5301	260,0	round key	hickory	10	3,90
140.5304	300,0	round key	hickory	160	2,90
140.5305	310,0	round key	hickory	60	3,90
140.5306	330,0	round key	hickory	60	4,90
142.5301	300,0	round key	hickory	10	4,90
142.5302	320,0	round key	hickory	160	4,90
142.5303	350,0	round key	hickory	120	4,90
142.5304	380,0	round key	hickory	160	5,90
142.5311	270,0	round key	hickory	100	3,90
142.5312	290,0	round key	hickory	100	3,90
142.5313	310,0	round key	hickory	100	4,90
142.5314	260,0	round key	hickory	60	3,90
142.5316	260,0	round key	hickory	100	4,90
142.5317	260,0	round key	hickory	110	4,90
142.5318	280,0	round key	hickory	100	4,90
140.5320	260,0	beveled	hickory	130	3,90
140.5322	280,0	beveled	hickory	130	3,50
140.5323	300,0	beveled	hickory	130	3,90
140.5330	700,0	beveled	hickory	440	12,90
140.5340	900,0	beveled	hickory	850	19,90
140.2067	350,0	round key	hickory	200	3,90
140.2068	380,0	round key	hickory	240	8,90
140.2069	700,0	round key	hickory	550	14,90
142.1510	290,0	round key	hickory	80	3,90
142.1520	310,0	round key	hickory	110	4,90
142.1530	350,0	round key	hickory	120	7,90
142.1540	365,0	round key	hickory	190	5,90
142.1550	380,0	round key	hickory	240	5,90
142.5305	260,0	round key	hickory	80	2,90
142.5306	280,0	round key	hickory	83	2,90
142.5307	300,0	round key	hickory	50	3,90
142.5308	320,0	round key	hickory	90	4,90
142.5309	350,0	round key	hickory	120	4,90
142.5310	360,0	round key	hickory	268	5,90



Replacement handles fiberglass

- Without wedge
- Tapered style form



	L mm	Handle form	Handle style	g	€
142.5315	370,0	beveled	fiberglass	220	4,90
142.5319	280,0	beveled	fiberglass	150	4,90
142.5332	900,0	beveled	fiberglass	800	17,90
142.5323	900,0	beveled	fiberglass	1010	15,90

ROUND KEY, LOCKING DEVICE

Round key, locking device

- For hammer and axe handles
- With barbed angel
- Aluminium



	D1 mm	D2 mm	g	€
140.5402	8,0	10,0	10	0,70
140.5404	10,0	12,0	10	0,80
140.5405	12,0	14,0	10	1,00
140.5408	17,0	23,0	10	0,90



FLAT CHISELS

Flat chisel

- 8-point
- Quenched and tempered
- Mirror polished
- Highly polished
- Chrome vanadium

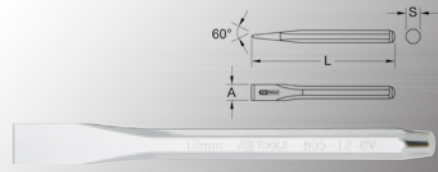

	L mm	A mm	S mm	Handle number	g	€
156.0162	130,0	12,0	9,0	-	70	3,90

Flat chisel with hand grip

- 8-point
- Quenched and tempered
- Tip can be re-sharpened
- Highly polished
- Chrome molybdenum

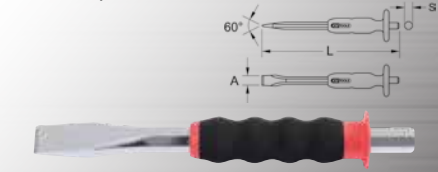

	L mm	A mm	S mm	g	€
156.0241	210,0	20,0	14,0	273	8,90

Flat chisel

- DIN 6453
- Flat oval form
- Blade can be resharpened
- Quenched and tempered
- Shaft with gold coated lacquer
- Highly polished
- Chrome molybdenum

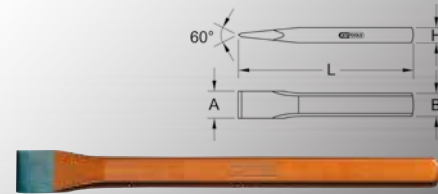

	L mm	A mm	B mm	H mm	Handle number	g	€
162.0101	100,0	18,0	14,0	9,0	-	80	7,90
162.0102	125,0	18,0	14,0	9,0	-	100	8,90
162.0103	150,0	21,0	17,0	11,0	-	180	6,90
162.0104	175,0	24,0	20,0	12,0	-	280	7,90
162.0105	200,0	28,0	23,0	13,0	162.0442	380	8,90
162.0106	250,0	28,0	23,0	13,0	162.0442	500	9,90
162.0107	300,0	31,0	23,0	13,0	162.0442	600	10,90

Flat chisel with hand grip

- DIN 6453
- Flat oval form
- Blade can be resharpened
- Quenched and tempered
- Shaft with gold coated lacquer
- Highly polished
- Chrome molybdenum

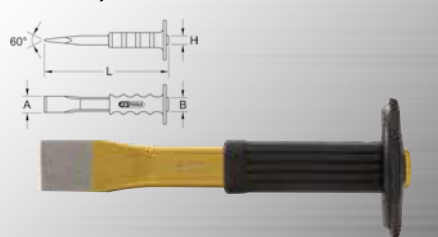

	L mm	A mm	B mm	H mm	g	€
162.0113	250,0	28,0	23,0	13,0	500	13,90
162.0114	300,0	31,0	23,0	13,0	600	15,90

Flat chisel

- 8-point
- Quenched and tempered
- Blade can be resharpened
- Shaft with gold coated lacquer
- Highly polished
- Chrome molybdenum

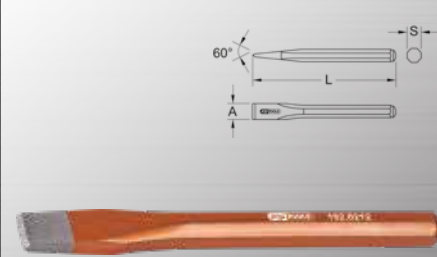

	L mm	A mm	S mm	Handle number	g	€
162.0211	125,0	13,0	10,0	-	80	7,90
162.0212	150,0	15,0	12,0	-	120	8,90



Flat chisel

- Flat oval form
- Blade can be resharpened
- Quenched and tempered
- Highly polished
- Chrome molybdenum

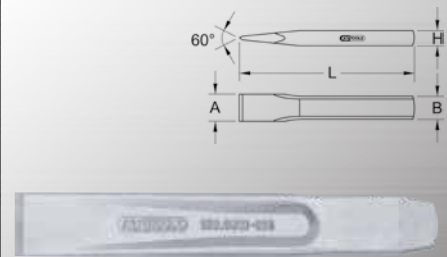

	L mm	A mm	B mm	H mm	Handle number	g	€
156.0691	125,0	19,0	13,0	8,0	-	81	4,90
156.0692	150,0	21,0	14,0	9,0	-	136	4,90
156.0693	200,0	27,0	17,0	11,0	-	244	6,90
156.0694	250,0	31,0	19,0	12,0	-	411	7,90

Flat chisel set

- Flat oval form
- Blade can be resharpened
- Quenched and tempered
- Highly polished
- Chrome molybdenum



	g	€
156.0690	4 pcs 125x19 - 150x21 - 200x27 - 250x31 mm	970 24,90

Flat chisel

- 6 point
- Heavy execution
- Dimensionally stable 25 mm six point shaft
- Ideal for preparation working
- For the preparation of truck rivets and welds
- Chiseling of rusted bolts and nuts is possible
- Special tool steel

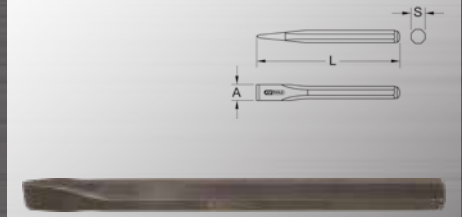

	L mm	A mm	S mm	g	€
450.0026	400,0	30,0	25,0	1,20	68,90
450.0027	600,0	30,0	25,0	2,64	105,90

Flat chisel set, heavy duty for commercial vehicle

- Heavy execution
- Dimensionally stable 25 mm six point shaft
- For the preparation of truck rivets and welds
- Ideal for preparation working
- Chiseling of rusted bolts and nuts is possible
- Ideally suited for commercial vehicles
- Special tool steel



	g	€
450.0025	2 pcs 400 - 600 mm	3,97 174,90



TILER'S FLAT CHISELS

Tilers flat chisel

- 4 point
- Quenched and tempered
- Blade can be resharpened
- Shaft with gold coated lacquer
- Highly polished
- Chrome molybdenum

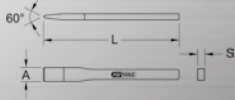

	L mm	A mm	S mm	Handle number	g	€
162.0311	100,0	10,0	8,0	-	40	5,90

SLITTING CHISEL

Slitting chisel

- Flat oval form
- Quenched and tempered
- Blade can be resharpened
- Shaft with gold coated lacquer
- Highly polished
- Chrome molybdenum

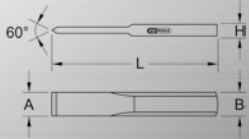

	L mm	A mm	B mm	H mm	Handle number	g	€
162.0131	230,0	26,0	26,0	7,0	162.0441	285	9,90

Slitting chisel with hand grip

- Flat oval form
- Quenched and tempered
- Blade can be resharpened
- Shaft with gold coated lacquer
- Highly polished
- Chrome molybdenum

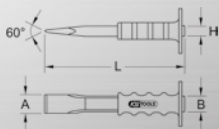

	L mm	A mm	B mm	H mm	g	€
162.0141	230,0	26,0	26,0	7,0	285	14,90

Panel beaters slitting chisel, extra thin

- Flat oval form
- Extra thin
- Blade can be resharpened
- Quenched and tempered
- Shaft with gold coated lacquer
- Highly polished
- Chrome molybdenum

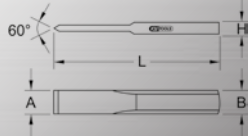

	L mm	A mm	B mm	H mm	Handle number	g	€
162.0421	240,0	26,0	26,0	7,0	162.0443	260	9,90

Slitting chisel with hand grip

- Flat oval form
- Extra thin
- Blade can be resharpened
- Quenched and tempered
- Shaft with gold coated lacquer
- Highly polished
- Chrome molybdenum



	L mm	A mm	B mm	H mm	g	€
162.0471	240,0	26,0	26,0	7,0	370	14,90

JOINTING CHISELS

Jointing chisel

- 8-point
- Quenched and tempered
- Blade can be resharpened
- Shaft with gold coated lacquer
- Highly polished
- Chrome molybdenum

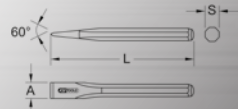

	L mm	A mm	S mm	Handle number	g	€
162.0151	250,0	25,0	18,0	162.0446	420	16,90
162.0152	250,0	100,0	20,0	162.0447	685	41,90

Jointing chisel with hand grip

- 8-point
- Quenched and tempered
- Blade can be resharpened
- Shaft with gold coated lacquer
- Highly polished
- Chrome molybdenum

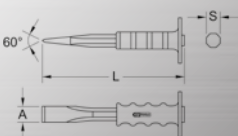

	L mm	A mm	S mm	g	€
162.0161	250,0	25,0	18,0	420	20,90
162.0162	250,0	100,0	20,0	685	43,90

Jointing chisel

- Flat oval form
- Quenched and tempered
- Blade can be resharpened
- Shaft with gold coated lacquer
- Highly polished
- Chrome molybdenum

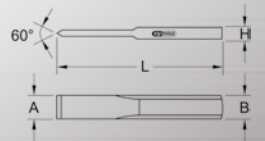

	L mm	A mm	B mm	H mm	Handle number	g	€
162.0171	250,0	50,0	23,0	13,0	162.0442	500	16,90
162.0172	250,0	60,0	26,0	13,0	162.0444	550	15,90
162.0173	250,0	70,0	26,0	13,0	162.0444	580	17,90

Jointing chisel with hand grip

- Flat oval form
- Quenched and tempered
- Blade can be resharpened
- Shaft with gold coated lacquer
- Highly polished
- Chrome molybdenum

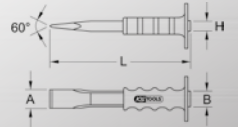

	L mm	A mm	B mm	H mm	g	€
162.0181	250,0	50,0	23,0	13,0	500	17,90
162.0182	250,0	60,0	26,0	13,0	550	19,90
162.0183	250,0	70,0	26,0	13,0	580	22,90



BRICKLAYERS CHISEL

Bricklayers chisel

- DIN 7254 form A
- Flat oval form
- Blade can be resharpened
- Quenched and tempered
- Shaft with gold coated lacquer
- Highly polished
- Chrome molybdenum

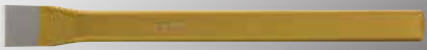
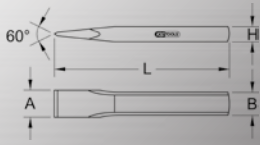

	L mm	A mm	B mm	H mm	Handle number	g	€
162.0191	200,0	27,0	20,0	12,0	162.0441	310	7,90
162.0192	250,0	27,0	20,0	12,0	162.0441	400	9,90
162.0193	300,0	31,0	23,0	13,0	162.0442	580	10,90
162.0194	350,0	31,0	23,0	13,0	162.0442	720	11,90
162.0195	400,0	31,0	23,0	13,0	162.0442	780	12,90
162.0196	500,0	33,0	26,0	13,0	162.0444	1160	17,90
162.0197	600,0	33,0	26,0	13,0	162.0444	1400	54,90
162.0198	800,0	33,0	26,0	13,0	162.0444	1860	77,90
162.0199	1000,0	33,0	26,0	13,0	162.0444	2360	103,90

Bricklayers chisel with hand grip

- DIN 7254 form A
- Flat oval form
- Blade can be resharpened
- Quenched and tempered
- Shaft with gold coated lacquer
- Highly polished
- Chrome molybdenum

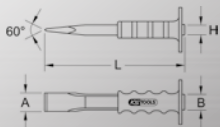

	L mm	A mm	B mm	H mm	g	€
162.0202	250,0	27,0	20,0	12,0	400	13,90
162.0203	300,0	31,0	23,0	13,0	580	16,90
162.0204	350,0	31,0	23,0	13,0	720	16,90
162.0205	400,0	31,0	23,0	13,0	800	18,90
162.0206	500,0	33,0	26,0	13,0	1160	24,90
162.0207	600,0	33,0	26,0	13,0	1400	57,90
162.0208	800,0	33,0	26,0	13,0	1860	80,90
162.0209	1000,0	33,0	26,0	13,0	2360	102,90

Bricklayers chisel

- DIN 7254 form B
- 8-point
- Blade can be resharpened
- Quenched and tempered
- Shaft with gold coated lacquer
- Highly polished
- Chrome molybdenum

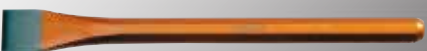
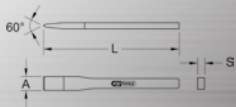

	L mm	A mm	S mm	Handle number	g	€
162.0481	200,0	27,0	16,0	162.0445	300	8,90
162.0482	250,0	27,0	16,0	162.0445	380	9,90
162.0483	300,0	30,0	18,0	162.0446	600	10,90
162.0484	350,0	30,0	18,0	162.0446	700	11,90
162.0485	400,0	30,0	20,0	162.0447	980	12,90
162.0486	500,0	30,0	20,0	162.0447	1240	42,90

Bricklayers chisel with hand grip

- DIN 7254 form B
- 8-point
- Blade can be resharpened
- With hand protection grip
- Quenched and tempered
- Shaft with gold coated lacquer
- Highly polished
- Chrome molybdenum

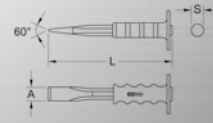

	L mm	A mm	S mm	g	€
162.0222	250,0	27,0	16,0	380	16,90
162.0223	300,0	30,0	18,0	600	10,90
162.0224	350,0	30,0	18,0	700	17,90
162.0225	400,0	30,0	20,0	980	18,90
162.0226	500,0	30,0	20,0	1240	50,90

POINTED CHISELS

Pointed chisel

- DIN 7256
- 8-point
- Tip can be re-sharpened
- Quenched and tempered
- Shaft with gold coated lacquer
- Highly polished
- Chrome molybdenum



	L mm	S mm	Handle number	g	€
162.0231	200,0	16,0	162.0445	280	7,90
162.0232	250,0	16,0	162.0445	360	9,90
162.0233	300,0	18,0	162.0446	560	10,90
162.0234	350,0	18,0	162.0446	660	12,90
162.0235	400,0	20,0	162.0447	940	15,90
162.0236	500,0	20,0	162.0447	1200	38,90
162.0237	600,0	20,0	162.0447	1480	49,90
162.0238	800,0	20,0	162.0447	1960	64,90
162.0239	1000,0	20,0	162.0447	2440	78,90

Pointed chisel with hand grip

- DIN 7256
- 8-point
- Tip can be re-sharpened
- Quenched and tempered
- Shaft with gold coated lacquer
- Highly polished
- Chrome molybdenum

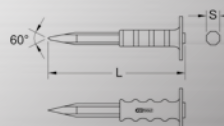

	L mm	S mm	g	€
162.0242	250,0	16,0	360	14,90
162.0243	300,0	18,0	560	16,90
162.0244	350,0	18,0	660	18,90
162.0245	400,0	20,0	940	20,90
162.0246	500,0	20,0	1200	43,90
162.0247	600,0	20,0	1480	51,90
162.0248	800,0	20,0	1960	70,90
162.0249	1000,0	20,0	2440	88,90



ELECTRICIANS CHISEL

Electricians chisel

- 4 point
- Quenched and tempered
- Blade can be resharpened
- Shaft with gold coated lacquer
- Highly polished
- Chrome molybdenum

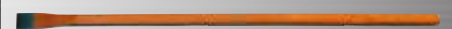

	L mm	A mm	S mm	Handle number	g	€
162.0251	200,0	8,0	6,0	-	60	4,90
162.0252	200,0	10,0	8,0	-	100	4,90
162.0253	200,0	12,0	8,0	-	101	5,90
162.0254	200,0	12,0	10,0	-	140	5,90
162.0255	250,0	10,0	8,0	-	120	5,90
162.0256	250,0	12,0	8,0	-	120	5,90
162.0257	250,0	12,0	10,0	-	185	6,90
162.0258	300,0	12,0	8,0	-	140	6,90

Electricians chisel

- 8-point
- Quenched and tempered
- Blade can be resharpened
- Shaft with gold coated lacquer
- Highly polished
- Chrome molybdenum

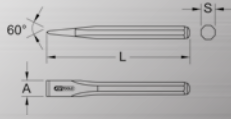

	L mm	A mm	S mm	Handle number	g	€
162.0261	200,0	12,0	10,0	-	120	5,90
162.0262	200,0	14,0	12,0	-	160	6,90
162.0263	250,0	12,0	10,0	-	150	6,90
162.0264	250,0	14,0	12,0	-	210	7,90
162.0265	300,0	12,0	10,0	-	200	8,90
162.0266	300,0	14,0	12,0	-	260	7,90

CROSS CHISEL

Cross chisel

- DIN 6451
- Flat oval form
- Tip can be re-sharpened
- Quenched and tempered
- Shaft with gold coated lacquer
- Highly polished
- Chrome molybdenum

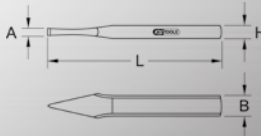

	L mm	A mm	B mm	H mm	Handle number	g	€
162.0281	100,0	5,0	14,0	9,0	-	60	7,90
162.0282	125,0	5,0	14,0	9,0	-	80	8,90
162.0283	150,0	6,0	17,0	11,0	-	160	6,90
162.0284	175,0	7,0	20,0	12,0	-	240	7,90
162.0285	200,0	8,0	23,0	13,0	162.0442	340	9,90
162.0286	250,0	8,0	23,0	13,0	162.0442	460	10,90
162.0287	300,0	9,0	23,0	13,0	162.0442	560	21,90

Cross chisel with hand grip

- DIN 6451
- Flat oval form
- Tip can be re-sharpened
- Quenched and tempered
- Shaft with gold coated lacquer
- Highly polished
- Chrome molybdenum

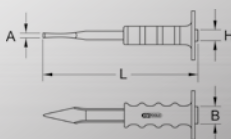

	L mm	A mm	B mm	H mm	g	€
162.0293	250,0	8,0	23,0	13,0	460	14,90
162.0294	300,0	9,0	23,0	13,0	560	25,90

Cross chisel

- 8-point
- Quenched and tempered
- Tip can be re-sharpened
- Shaft with gold coated lacquer
- Highly polished
- Chrome molybdenum

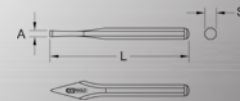

	L mm	A mm	S mm	Handle number	g	€
162.0301	125,0	4,0	10,0	-	60	7,90

Cross chisel

- 8-point
- Quenched and tempered
- Mirror polished
- Highly polished
- Chrome vanadium

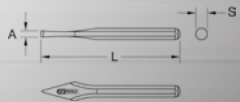

	L mm	A mm	S mm	Handle number	g	€
156.0161	130,0	5,0	10,0	-	60	3,90

Cross chisel with hand grip

- 8-point
- Quenched and tempered
- Tip can be re-sharpened
- Highly polished
- Chrome molybdenum

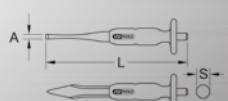

	L mm	A mm	S mm	g	€
156.0242	190,0	7,0	12,0	169	6,90



TILERS POINTED CHISELS

Tilers pointed chisel

- 4 point
- Quenched and tempered
- Blade can be resharpened
- Shaft with gold coated lacquer
- Highly polished
- Chrome molybdenum

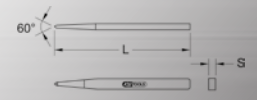

	L mm	S mm	Handle number	g	€
162.0321	100,0	8,0	-	40	6,90
162.0322	200,0	6,0	-	60	7,90
162.0323	200,0	8,0	-	100	7,90
162.0324	250,0	8,0	-	120	8,90
162.0325	250,0	10,0	-	180	8,90

PARTING CHISEL

Bodywork slitting chisel

- Flat oval form
- Quenched and tempered
- Blade can be resharpened
- Shaft with gold coated lacquer
- Highly polished
- Chrome molybdenum



	L mm	A mm	B mm	H mm	Handle number	g	€
162.0271	250,0	30,0	23,0	13,0	162.0442	460	40,90

Bodywork slitting chisel

- DIN 7255
- Flat oval form
- Blade can be resharpened
- Extra flat
- Burnished
- Chrome vanadium

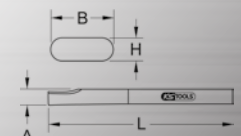

	L mm	A mm	B mm	H mm	Handle number	g	€
140.2162	300,0	21,0	25,0	6,0	-	310	29,90

Bodywork slitting chisel with hand grip

- DIN 7255
- Flat oval form
- Blade can be resharpened
- Extra flat
- Burnished
- Chrome vanadium

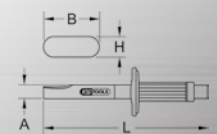

	L mm	A mm	B mm	H mm	g	€
140.2165	300,0	21,0	25,0	6,0	550	35,90

Bodywork spade chisel

- Extra wide execution
- With protective handgrip
- Quenched and tempered
- For cutting metal sheet and spot welds
- Shaft with powder coated lacquer
- Special tool steel



	B mm	L mm	g	€
156.0330	60,0	240,0	600	25,90

Bodywork slitting chisel

- Suitable for separating welds
- With re-grindable cutters
- Continuous blade
- Two component handle
- Special tool steel

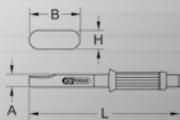

	L mm	A mm	B mm	H mm	g	€
162.0216	300,0	25,0	19,0	6,0	330	19,90

Bodywork slitting chisel

- Suitable for separating welds
- With re-grindable cutters
- Continuous blade
- Two component handle
- Special tool steel

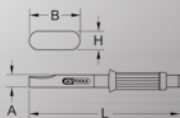

	L mm	A mm	B mm	H mm	g	€
162.0217	300,0	25,0	19,0	6,0	330	21,90

Bodywork slitting chisel

- Suitable for separating welds
- With re-grindable cutters
- Continuous blade
- Two component handle
- Special tool steel

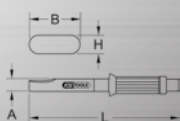

	L mm	A mm	B mm	H mm	g	€
162.0218	240,0	25,0	19,0	6,0	330	22,90

BOLSTER CHISEL

Bolster chisel

- Flat oval form
- Quenched and tempered
- Blade can be resharpened
- Shaft gold lacquer
- Carbon manganese silicon steel



	L mm	A mm	Handle number	H mm	g	€
162.0431	200,0	60,0	-	15,0	500	41,90
162.0432	200,0	80,0	-	15,0	600	49,90
162.0433	220,0	100,0	-	18,0	750	57,90
162.0434	220,0	120,0	-	18,0	900	70,90

GLASS FIBRE CHISELS

Glassfibre chisel

- For paint preserving removal of ornament and window strips and wheel weights on aluminium rims
- With impact cap for light impacts
- Special shape of the bit handle ensures safe work
- With flexible flat scraper and cutting edge
- Also suitable for the removal of labels, adhesive and type plates
- Surfaces are not damaged
- Sharpened with a file
- Solvent-resistant
- Special plastic

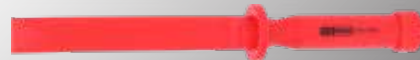

	Blade width mm	g	€
911.8131	19,0	130	8,90
911.8132	22,0	140	8,90
911.8133	25,0	150	9,90
911.8134	38,0	180	10,90

Glassfibre chisel set

- For paint preserving removal of ornament and window strips and wheel weights on aluminium rims
- With impact cap for light impacts
- Special shape of the bit handle ensures safe work
- With flexible flat scraper and cutting edge
- Also suitable for the removal of labels, adhesive and type plates
- Surfaces are not damaged
- Sharpened with a file
- Solvent-resistant
- Special plastic



	g	€
911.8130	4 pcs 19 - 22 - 26 - 38 mm	570 31,90

HAND GRIPS

Hand grip for chisel

- Standard version
- PVC



	L mm	D mm	Handle size mm	g	€
162.0441	120,0	80,0	20x12	110	3,90
162.0442	120,0	80,0	23x13	110	4,90
162.0443	120,0	80,0	26x7	110	3,90
162.0444	120,0	80,0	26x13	110	4,90
162.0445	120,0	80,0	16	110	4,90
162.0446	120,0	80,0	18	110	4,90
162.0447	120,0	80,0	20	110	4,90

Safety hand grip for chisel

- Double hand protection
- PVC



	L mm	D mm	Handle size mm	g	€
162.2128	140,0	100,0	23x13	170	12,90
162.2129	140,0	100,0	20	170	12,90
162.2130	140,0	100,0	26x7	170	12,90
162.2132	140,0	100,0	26x13	170	12,90

PIN PUNCHES

Pin punch

- DIN 6458 form B
- 8-point
- Tip can be re-sharpened
- Quenched and tempered
- Shaft with gold coated lacquer
- Highly polished
- Chrome molybdenum

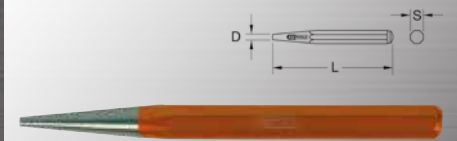

	L mm	D mm	S mm	Handle number	g	€
162.0331	120,0	1,0	10,0	-	65	2,90
162.0332	120,0	2,0	10,0	-	65	2,90
162.0333	120,0	3,0	10,0	-	65	2,90
162.0334	120,0	4,0	10,0	-	65	2,90
162.0335	120,0	5,0	10,0	-	65	2,90
162.0336	120,0	6,0	10,0	-	65	2,90

Pin punch

- DIN 6458 form D
- 8-point
- Tip can be re-sharpened
- Quenched and tempered
- Shaft with gold coated lacquer
- Highly polished
- Chrome molybdenum

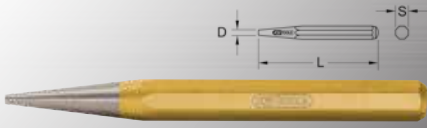

	L mm	D mm	S mm	Handle number	KS	€
162.0341	120,0	1,0	12,0	-	85	5,90
162.0342	120,0	2,0	12,0	-	85	5,90
162.0343	120,0	3,0	12,0	-	85	5,90
162.0344	120,0	4,0	12,0	-	90	5,90
162.0345	120,0	5,0	12,0	-	90	5,90
162.0346	120,0	6,0	12,0	-	90	5,90
162.0347	120,0	7,0	12,0	-	95	5,90
162.0348	120,0	8,0	12,0	-	95	5,90
162.0349	120,0	9,0	12,0	-	100	5,90
162.0350	120,0	10,0	12,0	-	105	5,90
162.0352	150,0	12,0	16,0	-	220	14,90

Pin punch with hollow tip

- DIN 6458
- 8-point
- Tip can be re-sharpened
- Quenched and tempered
- Shaft with gold coated lacquer
- Highly polished
- Chrome molybdenum

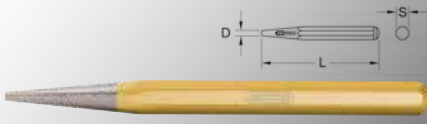

	L mm	D mm	S mm	Handle number	KS	€
162.0461	120,0	1,0	10,0	-	65	3,90
162.0462	120,0	2,0	10,0	-	65	3,90
162.0463	120,0	3,0	10,0	-	65	3,90
162.0464	120,0	4,0	10,0	-	65	3,90
162.0465	120,0	5,0	10,0	-	65	3,90
162.0466	120,0	6,0	10,0	-	65	3,90

Punch set for trucks

- Conical tapered point
- Universal usage
- For extracting cotter pins, bolts, bearing rings etc.
- Ideally suited for daily workshop use
- High quality and substantial construction
- Premium tempered and hardened steel
- Special steel



	KS	€
450.0090 4 pcs 6,4 - 6,4 - 8,0 - 13,0 mm	2,91	75,90

Truck punch

- Conical tapered point
- Universal usage
- For extracting cotter pins, bolts, bearing rings etc.
- Ideally suited for daily workshop use
- High quality and substantial construction
- Premium tempered and hardened steel
- Special steel



	Ø mm	L mm	KS	€
450.0091	6,4	300,0	390	20,90
450.0092	6,4	380,0	730	25,90
450.0093	8,0	300,0	410	27,90
450.0094	13,0	460,0	1310	44,90

Pin punch

- 8-point
- Quenched and tempered
- Mirror polished
- Highly polished
- Chrome vanadium

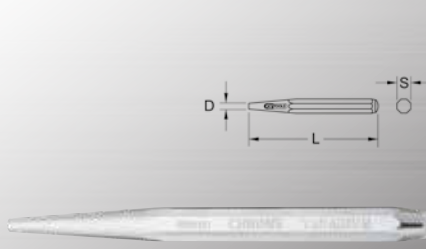

	L mm	D mm	S mm	Handle number	KS	€
156.0130	120,0	2,0	9,5	-	60	2,40
156.0131	120,0	3,0	9,5	-	60	1,90
156.0132	120,0	4,0	9,5	-	60	2,30
156.0133	120,0	5,0	9,5	-	60	2,40
156.0134	120,0	6,0	9,5	-	60	2,40

Pin punches with hand grip

- 8-point
- Quenched and tempered
- Tip can be re-sharpened
- Highly polished
- Chrome molybdenum

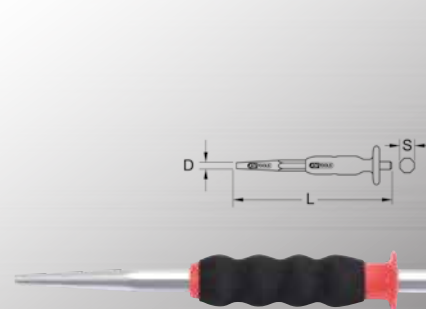

	L mm	D mm	S mm	KS	€
156.0244	185,0	5,0	10,0	115	5,90

Pin punch set

- DIN 6458 Form B+D
- 8-point
- Quenched and tempered
- Tip can be re-sharpened
- Shaft with gold coated lacquer
- Highly polished
- Chrome molybdenum
- In a plastic bag



	KS	€
162.2126 6 pcs 120x10x1 - 120x10x2 - 120x10x3 - 120x10x4 - 120x10x5 - 120x10 mm	465	24,90

Pin punch set

- DIN 6458 Form B+D
- 8-point
- Quenched and tempered
- Tip can be re-sharpened
- Shaft with gold coated lacquer
- Highly polished
- Chrome molybdenum
- In plastic stands



	KS	€
162.2127 6 pcs 120x10x1 - 120x10x2 - 120x10x3 - 120x10x4 - 120x10x5 - 120x10 mm	465	26,90

Pin punch set

- DIN 6458 Form B+D
- 8-point
- Quenched and tempered
- Tip can be re-sharpened
- Shaft with gold coated lacquer
- Highly polished
- Chrome molybdenum
- In metal storage cassette



	KS	€
162.2124 6 pcs 120x10x1 - 120x10x2 - 120x10x3 - 120x10x4 - 120x10x5 - 120x10 mm	710	27,90

COTTER PIN DRIVES

Cotter pin drive, long

- 8-point
- Quenched and tempered
- Tip can be re-sharpened
- Shaft with gold coated lacquer
- Highly polished
- Chrome molybdenum



	L1 mm	L2 mm	D mm	S mm	Handle number	KS	€
162.0391	175,0	80,0	3,0	10,0	-	60	3,90
162.0392	175,0	80,0	4,0	10,0	-	70	3,90
162.0393	175,0	80,0	5,0	10,0	-	80	3,90
162.0394	175,0	80,0	6,0	10,0	-	90	3,90
162.0395	175,0	80,0	8,0	12,0	-	140	4,90
162.0396	175,0	80,0	10,0	12,0	-	150	4,90

Pin punches with hand grip

- Round
- Quenched and tempered
- Tip can be re-sharpened
- Burnished
- Chrome vanadium

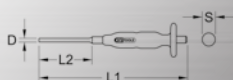

	L1 mm	L2 mm	D mm	S mm	g	€
156.0026	270,0	110,0	6,0	10,0	130	9,90
156.0028	300,0	130,0	8,0	12,0	220	11,90
156.0030	300,0	140,0	10,0	12,0	250	11,90
156.0032	300,0	140,0	12,0	14,0	340	15,90
156.0034	300,0	140,0	14,0	16,0	450	18,90

Pin punch set with hand protection grip

- Quenched and tempered
- Tip can be re-sharpened
- Burnished
- Chrome vanadium
- In metal stand with the possibility of wall hanging



	g	€
156.0020 5 pcs 270x6 - 300x8 - 300x10 - 300x12 - 300x14 mm	2,70	85,90

Pin punch, extra long

- 8-point
- Quenched and tempered
- Tip can be re-sharpened
- Shaft with gold coated lacquer
- Highly polished
- Chrome molybdenum

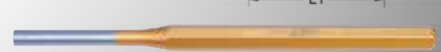
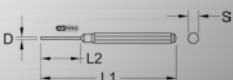

	L1 mm	L2 mm	D mm	S mm	Handle number	g	€
162.0401	200,0	40,0	2,0	10,0	-	82	4,90
162.0402	200,0	50,0	3,0	10,0	-	90	4,90
162.0403	200,0	55,0	4,0	10,0	-	92	4,90
162.0404	200,0	55,0	5,0	10,0	-	96	4,90
162.0405	200,0	55,0	6,0	12,0	-	100	4,90
162.0406	200,0	55,0	8,0	12,0	-	150	5,90
162.0407	200,0	55,0	10,0	12,0	-	165	5,90

Brake pad cotter pin drive with guide tip

- 8-point
- Extra long execution
- Quenched and tempered
- With guide pin for locking pins
- Suitable for locking pins on vehicles with disk brakes
- Shaft with gold coated lacquer
- Highly polished
- Chrome molybdenum

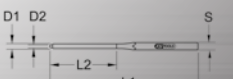

	L1 mm	L2 mm	D1 mm	D2 mm	S mm	Handle number	g	€
162.0411	175,0	85,0	4,0	2,7	10,0	-	60	4,90
162.0412	175,0	85,0	6,0	3,8	10,0	-	70	4,90

Brake pad cotter pin drive with guide tip

- 6 point
- Extra long execution
- Quenched and tempered
- 150.2151 with guide pin for locking pins
- Suitable for locking pins on vehicles with disk brakes
- Shaft with gold coated lacquer
- Highly polished
- Chrome molybdenum

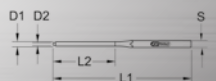

	L1 mm	L2 mm	D1 mm	D2 mm	S mm	Handle number	g	€
150.2150	180,0	80,0	4,0	-	10,0	-	70	3,90
150.2151	175,0	80,0	5,8	3,1	10,0	-	70	4,90

Pin punch with hand protection grip

- Round
- Quenched and tempered
- Tip can be re-sharpened
- Burnished
- Chrome vanadium

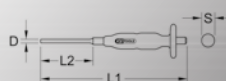

	L1 mm	L2 mm	D mm	S mm	g	€
156.0002	130,0	30,0	3,0	8,0	50	5,90
156.0003	145,0	40,0	3,0	8,0	60	5,90
156.0004	180,0	50,0	4,0	8,0	100	6,90
156.0005	180,0	60,0	5,0	10,0	100	6,90
156.0006	205,0	80,0	6,0	10,0	130	6,90
156.0008	225,0	85,0	8,0	12,0	150	8,90
156.0010	225,0	90,0	10,0	12,0	200	9,90

Pin punch set with hand protection grip

- With wall mounting possibility
- Tip can be re-sharpened
- Quenched and tempered
- Burnished
- Chrome vanadium
- In metal stand



	g	€
156.0000 5 pcs 145x3 - 180x4 - 180x5 - 205x6 - 225x8 mm	650	53,90



Pin punch

- 8-point
- Quenched and tempered
- Mirror polished
- Highly polished
- Chrome vanadium

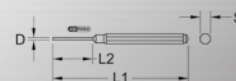

	L1 mm	L2 mm	D mm	S mm	Handle number	g	€
156.0111	115,0	30,0	2,0	8,0	-	40	3,90
156.0112	125,0	40,0	3,0	8,0	-	40	2,90
156.0113	150,0	50,0	4,0	9,5	-	60	2,90
156.0114	165,0	50,0	5,0	9,5	-	70	2,90
156.0115	180,0	55,0	6,0	12,7	-	140	4,90
156.0116	180,0	55,0	8,0	12,7	-	150	4,90

	L1 mm	L2 mm	D mm	S mm	Handle number	g	€
156.0111	115,0	30,0	2,0	8,0	-	40	3,90
156.0112	125,0	40,0	3,0	8,0	-	40	2,90
156.0113	150,0	50,0	4,0	9,5	-	60	2,90
156.0114	165,0	50,0	5,0	9,5	-	70	2,90
156.0115	180,0	55,0	6,0	12,7	-	140	4,90
156.0116	180,0	55,0	8,0	12,7	-	150	4,90

Pin punch set

- Quenched and tempered
- Mirror polished
- Highly polished
- Chrome vanadium
- In plastic support bracket



	g	€
156.0150 6 pcs 115x2 - 125x3 - 150x4 - 165x5 - 180x6 - 180x8 mm	520	22,90

Pin punch, extra long

- 8-point
- Quenched and tempered
- Mirror polished
- Highly polished
- Chrome vanadium

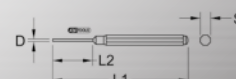

	L1 mm	L2 mm	D mm	S mm	Handle number	g	€
156.0121	200,0	80,0	3,0	9,5	-	70	5,90
156.0122	200,0	85,0	4,0	9,5	-	70	4,90
156.0123	200,0	90,0	5,0	9,5	-	80	4,90
156.0124	200,0	93,0	6,0	9,5	-	80	4,90
156.0125	200,0	93,0	8,0	12,7	-	150	4,90
156.0126	200,0	93,0	10,0	12,7	-	170	4,90

	L1 mm	L2 mm	D mm	S mm	Handle number	g	€
156.0121	200,0	80,0	3,0	9,5	-	70	5,90
156.0122	200,0	85,0	4,0	9,5	-	70	4,90
156.0123	200,0	90,0	5,0	9,5	-	80	4,90
156.0124	200,0	93,0	6,0	9,5	-	80	4,90
156.0125	200,0	93,0	8,0	12,7	-	150	4,90
156.0126	200,0	93,0	10,0	12,7	-	170	4,90

Pin punch set

- 8-point
- Quenched and tempered
- Mirror polished
- Highly polished
- Chrome vanadium
- In metal stand with the possibility of wall hanging



	kg	€
156.0180 17 pcs Pin punch set	1,00	66,90

consists of:

	kg	€
156.0111 Pin punch octagonal shaft, mirror polished, Ø 2mm	40	
156.0112 Pin punch octagonal shaft, mirror polished, Ø 3mm	40	
156.0113 Pin punch octagonal shaft, mirror polished, Ø 4mm	60	
156.0114 Pin punch octagonal shaft, mirror polished, Ø 5mm	70	
156.0115 Pin punch octagonal shaft, mirror polished, Ø 6mm	140	
156.0116 Pin punch octagonal shaft, mirror polished, Ø 8mm	150	
156.0121 Pin punch octagonal shaft, mirror polished, extra long, Ø 3mm	70	
156.0122 Pin punch octagonal shaft, mirror polished, extra long, Ø 4mm	70	
156.0123 Pin punch octagonal shaft, mirror polished, extra long, Ø 5mm	80	
156.0124 Pin punch octagonal shaft, mirror polished, extra long, Ø 6mm	80	
156.0125 Pin punch octagonal shaft, mirror polished, extra long, Ø 8mm	150	
156.0126 Pin punch octagonal shaft, mirror polished, extra long, Ø 10mm	170	
156.0130 Pin punch, Ø 2mm	60	
156.0131 Pin punch, Ø 3mm	60	
156.0132 Pin punch, Ø 4mm	60	
156.0133 Pin punch, Ø 5mm	60	
156.0134 Pin punch, Ø 6mm	60	

Combi tool set

- Quenched and tempered
- Mirror polished
- Highly polished
- Chrome vanadium
- In plastic support bracket



	kg	€
156.0160 5 pcs Combi tool set	360	14,90

consists of:

	kg	€
156.0113 Pin punch octagonal shaft, mirror polished, Ø 4mm	60	
156.0131 Pin punch, Ø 3mm	60	
156.0175 Centre punch, mirror polished, octagonal shaft, Ø 5mm	60	
156.0162 Flat chisel, octagonal shaft, 130mm	70	
156.0161 Cross chisel, 130mm	60	

Pin punches with hand grip

- Round
- Quenched and tempered
- Two component handle
- Tip can be re-sharpened
- Tip polished, shaft burnished
- Chrome vanadium



	D mm	L1 mm	L2 mm	S mm	kg	€
156.0211	2,0	150,0	30,0	10,0	100	5,90
156.0212	3,0	150,0	40,0	10,0	100	5,90
156.0213	4,0	150,0	55,0	10,0	100	5,90
156.0214	5,0	150,0	60,0	10,0	100	5,90
156.0215	6,0	150,0	60,0	10,0	100	5,90
156.0216	7,0	150,0	60,0	12,0	110	6,90
156.0217	8,0	150,0	60,0	12,0	110	6,90
156.0218	9,0	150,0	60,0	12,0	110	6,90
156.0219	10,0	150,0	60,0	12,0	130	6,90

Pin punch set with hand protection grip

- Round
- Quenched and tempered
- Two component handle
- Tip can be re-sharpened
- Tip polished, shaft burnished
- Chrome vanadium



	kg	€
156.0220 5 pcs 3 - 4 - 5 - 6 - 8 mm	800	41,90

Pin punch, cylindrical shaft

- Quenched and tempered
- Tip can be re-sharpened
- Highly polished
- Chrome molybdenum



	L1 mm	L2 mm	D mm	S mm	kg	€
156.0231	150,0	50,0	3,0	8,0	52	3,90
156.0232	180,0	61,0	4,0	10,0	93	4,90
156.0233	200,0	61,0	5,0	10,0	109	4,90
156.0234	210,0	71,0	6,0	12,0	160	6,90
156.0235	220,0	85,0	8,0	12,0	172	7,90



Punch set, cylindrical shaft

- Quenched and tempered
- Tip can be re-sharpened
- Highly polished
- Chrome molybdenum



	kg	€
156.0230 5 pcs 3 - 4 - 5 - 6 - 8 mm	715	32,90

Chisel and punch set

- Quenched and tempered
- Tip can be re-sharpened
- Highly polished
- Chrome molybdenum



	kg	€
156.0240 5 pcs Chisel and punch set	900	36,90

consists of:

	kg	€
156.0232 Pin punch, cylindrical shaft, 4mm	93	
156.0241 Flat chisel, octagon, 20mm	273	
156.0242 Cross chisel, octagon, 7mm	169	
156.0243 Centre punch, octagon 10mm	118	
156.0244 Punch, Ø 5 mm, conical	115	

Cotter pin drive with guide sleeve

- Guide sleeve, coded
- Ø 0.9 to 4.9 mm with loose guide sleeve
- Ø 5.9 mm with fixed sleeve
- Highly polished
- Chrome vanadium



	L mm	D mm	S mm	kg	€
162.2249	70,0	0,9	5,0	15	5,90
162.2250	80,0	1,4	6,0	21	5,90
162.2251	83,0	1,8	6,0	21	5,90
162.2252	92,0	2,4	7,0	30	5,90
162.2253	94,0	2,8	7,0	30	5,90
162.2254	100,0	3,4	8,0	35	5,90
162.2255	100,0	3,9	8,0	35	5,90
162.2256	110,0	4,9	10,0	45	5,90
162.2257	115,0	5,9	12,0	68	5,90

Cotter pin drive set with guide sleeve

- Guide sleeve, coded
- Ø 0.9 to 4.9 mm with loose guide sleeve
- Ø 5.9 mm with fixed sleeve
- Highly polished
- Chrome vanadium
- In a plastic bag



		g		€
162.2310	8 pcs	70x0,9 - 80x1,4 - 83x1,8 - 92x2,4 - 94x2,8 - 100x3,4 - 100x3,9 - 115x5,9 mm	240	53,90

Pin punch

- DIN 6450 form C
- 8-point
- Tip can be re-sharpened
- Quenched and tempered
- Shaft with gold coated lacquer
- Highly polished
- Chrome molybdenum

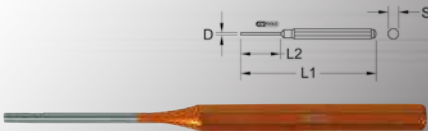

	L1 mm	L2 mm	D mm	S mm	Handle number	g	€
162.0371	150,0	35,0	2,0	10,0	-	60	2,90
162.0372	150,0	40,0	2,5	10,0	-	60	2,90
162.0373	150,0	40,0	3,0	10,0	-	60	2,90
162.0374	150,0	40,0	3,5	10,0	-	65	2,90
162.0375	150,0	50,0	4,0	10,0	-	65	2,90
162.0376	150,0	50,0	4,5	10,0	-	65	2,90
162.0377	150,0	50,0	5,0	10,0	-	65	2,90
162.0378	150,0	50,0	6,0	10,0	-	70	2,90
162.0379	150,0	55,0	7,0	10,0	-	95	3,90
162.0380	150,0	55,0	8,0	12,0	-	100	3,90
162.0381	150,0	55,0	9,0	12,0	-	110	3,90
162.0382	150,0	55,0	10,0	12,0	-	115	3,90
162.0383	150,0	55,0	12,0	16,0	-	170	17,90

Pin punch set

- Quenched and tempered
- Tip can be re-sharpened
- Shaft with gold coated lacquer
- Highly polished
- Chrome molybdenum
- In a plastic bag



		g		€
162.2122	6 pcs	150x10x3 - 150x10x4 - 150x10x5 - 150x10x6 - 150x12x8 - 150x12x10 mm	470	28,90

Pin punch set

- Quenched and tempered
- Tip can be re-sharpened
- Shaft with gold coated lacquer
- Highly polished
- Chrome vanadium
- In plastic support bracket



		g		€
162.2123	6 pcs	150x10x3 - 150x10x4 - 150x10x5 - 150x10x6 - 150x12x8 - 150x12x10 mm	470	29,90

Pin punch set

- Quenched and tempered
- Tip can be re-sharpened
- Shaft with gold coated lacquer
- Highly polished
- Chrome vanadium
- In metal storage box



		g		€
162.0370	6 pcs	150x10x3 - 150x10x4 - 150x10x5 - 150x10x6 - 150x12x8 - 150x12x10mm	750	31,90

Combination set

- Evenly hardened and carefully tempered through the whole length
- Impact heads inductively tempered
- Working ends polished ground and clear lacquered
- Chrome vanadium
- In metal storage cassette



		g		€
162.2114	6 pcs	Combination set	740	36,90

consists of:

		g	
162.0212	Flat chisel, 8 point, 150mm	120	
162.0301	Cross chisel, 8 point, 4x125mm	60	
162.0361	Centre punch, 8 point, Ø 4mm	65	
162.0375	Pin punch, 8 point, Ø 4mm	65	
162.0333	Pin punch, 8 point, formB, Ø 3mm	65	
162.0345	Pin punch, 8 point, formD, Ø 5mm	90	

Combination set

- Evenly hardened and carefully tempered through the whole length
- Impact heads inductively tempered
- Working ends polished ground and clear lacquered
- In a plastic bag



		g		€
162.2117	6 pcs	Combination set	510	33,90

consists of:

		g	
162.0212	Flat chisel, 8 point, 150mm	120	
162.0301	Cross chisel, 8 point, 4x125mm	60	
162.0361	Centre punch, 8 point, Ø 4mm	65	
162.0375	Pin punch, 8 point, Ø 4mm	65	
162.0333	Pin punch, 8 point, formB, Ø 3mm	65	
162.0345	Pin punch, 8 point, formD, Ø 5mm	90	

Combination set

- Evenly hardened and carefully tempered through the whole length
- Impact heads inductively tempered
- Working ends polished ground and clear lacquered
- In plastic support bracket



		g		€
162.2118	6 pcs	Combination set	510	34,90

consists of:

		g	
162.0212	Flat chisel, 8 point, 150mm	120	
162.0301	Cross chisel, 8 point, 4x125mm	60	
162.0361	Centre punch, 8 point, Ø 4mm	65	
162.0375	Pin punch, 8 point, Ø 4mm	65	
162.0333	Pin punch, 8 point, formB, Ø 3mm	65	
162.0345	Pin punch, 8 point, formD, Ø 5mm	90	

BEARING AND BUSH DRIVER

Brass and aluminium punch

- For extracting bearing, bolts and bushes etc.
- Rimed handle for better control
- Brass / Aluminium



	Material	Ø mm	Length mm	kg	€
156.0415	brass	20,0	300,0	1,13	42,90
156.0416	aluminium	30,0	300,0	1,89	25,90

Bearing punch set Ø 10.0 - 14.0 mm

- In durable plastic storage case



	kg	€
156.0440 10 pcs Bearing punch set Ø 10.0 - 14.0 mm	240	67,90

consists of:

	kg
156.0436 Punch holder without impact, with hand protection	100
156.0441 Polyamide punch adaptor set, 2 pcs, Ø 10mm	10
156.0442 Polyamide punch adaptor set, 2 pcs, Ø 12mm	10
156.0443 Polyamide punch adaptor set, 2 pcs, Ø 14mm	10
156.0449 Aluminium punch adaptor set, 2 pcs, Ø 10mm	10
156.0450 Aluminium punch adaptor set, 2 pcs, Ø 12mm	10
156.0451 Aluminium punch adaptor set, 2 pcs, Ø 14mm	20
156.0457 Brass punch adaptor set, 2 pcs, Ø 10mm	20
156.0458 Brass punch adaptor set, 2 pcs, Ø 12mm	20
156.0459 Brass punch adaptor set, 2 pcs, Ø 14mm	50

Bearing punch set Ø 25.0 mm

- In durable plastic storage case



	kg	€
156.0425 7 pcs Bearing punch set Ø 25.0 mm	640	63,90

consists of:

	kg
156.0426 Punch holder without impact	360
156.0447 Polyamide punch adaptor set, 2 pcs, Ø 25mm	20
156.0455 Aluminium punch adaptor set, 2 pcs, Ø 25mm	50
156.0463 Brass punch adaptor set, 2 pcs, Ø 25mm	150

Universal bearing and bush driver set

- Universal applicable range
- Can be used manually with a hammer or workshop press
- Applications from 18.0 - 65.0 mm
- Pressure plates are for the two driving spindles
- Special tool steel
- In durable plastic storage case



	kg	€
700.1350 51 pcs Universal bearing and bush driver set	8,00	369,00

consists of:

	kg
700.1348 Reception adaptor, 45mm	500
700.1349 Impact drive knurled grip, 220mm	42
700.1351 Pressure plate, 18mm	12
700.1352 Pressure plate, 19mm	14
700.1353 Pressure plate, 20mm	16
700.1354 Pressure plate, 21mm	20
700.1355 Pressure plate, 22mm	22
700.1356 Pressure plate, 23mm	27
700.1357 Pressure plate, 24mm	30
700.1358 Pressure plate, 25mm	34
700.1359 Pressure plate, 26mm	38
700.1360 Pressure plate, 27mm	43
700.1361 Pressure plate, 28mm	47
700.1362 Pressure plate, 29mm	50
700.1363 Pressure plate, 30mm	53
700.1364 Pressure plate, 31mm	59
700.1365 Pressure plate, 32mm	65
700.1366 Pressure plate, 33mm	68
700.1367 Pressure plate, 34mm	72
700.1368 Pressure plate, 35mm	77
700.1369 Pressure plate, 36mm	82
700.1370 Pressure plate, 37mm	89
700.1371 Pressure plate, 38mm	94
700.1372 Pressure plate, 39mm	97
700.1373 Pressure plate, 40mm	105
700.1374 Pressure plate, 41mm	111
700.1375 Pressure plate, 42mm	119
700.1376 Pressure plate, 43mm	125
700.1377 Pressure plate, 44mm	132
700.1378 Pressure plate, 45mm	138
700.1379 Pressure plate, 46mm	144
700.1380 Pressure plate, 47mm	153
700.1381 Pressure plate, 48mm	159
700.1382 Pressure plate, 49mm	165
700.1383 Pressure plate, 50mm	172
700.1384 Pressure plate, 51mm	181
700.1385 Pressure plate, 52mm	188
700.1386 Pressure plate, 53mm	196
700.1387 Pressure plate, 54mm	205
700.1388 Pressure plate, 55mm	213
700.1389 Pressure plate, 56mm	221

consists of:

	kg
700.1390 Pressure plate, 57mm	231
700.1391 Pressure plate, 58mm	238
700.1392 Pressure plate, 59mm	247
700.1393 Pressure plate, 60mm	258
700.1394 Pressure plate, 61mm	266
700.1395 Pressure plate, 62mm	276
700.1396 Pressure plate, 63mm	284
700.1397 Pressure plate, 64mm	294
700.1398 Pressure plate, 65mm	305
700.1399 Support plate, 74mm	500

Universal bearing and bush driver set

- for gentle driving of bearing and radial sealing rings
- Universal applicable range
- Can be used manually with a hammer or workshop press
- Applications from 70.0 - 150.0 mm
- Pressure plates are for the two driving spindles
- Special tool steel
- In durable plastic storage case



	kg	€
150.9710 21 pcs Universal bearing and bush driver set	19,13	735,90

consists of:

	kg
150.9712 Adaptor for Hydraulic thrust bolt, 45,5 mm	44
150.9713 Retaining adapter, 55 mm	217
150.9714 Repellent spike with knurling, 273,0 mm	1077
150.9715 Pressure plate, 70 mm	353
150.9716 Pressure plate, 75 mm	406
150.9717 Pressure plate, 80 mm	465
150.9718 Pressure plate, 85 mm	524
150.9719 Pressure plate, 90 mm	593
150.9720 Pressure plate, 95 mm	659
150.9721 Pressure plate, 100 mm	733
150.9722 Pressure plate, 105 mm	812
150.9723 Pressure plate, 110 mm	893
150.9724 Pressure plate, 115 mm	977
150.9725 Pressure plate, 120 mm	1065
150.9726 Pressure plate, 125 mm	1157
150.9727 Pressure plate, 130 mm	1255
150.9728 Pressure plate, 135 mm	1349
150.9729 Pressure plate, 140 mm	1457
150.9730 Pressure plate, 145 mm	1563
150.9731 Pressure plate, 150 mm	1676
151.2603 Hexagon key wrench phosphate finish, short, 3mm	10



CENTRE PUNCH

Centre punch

- Round
- Quenched and tempered
- Tip can be re-sharpened
- Black lacquer
- Chrome vanadium



	L mm	D mm	S mm	Handle number	g	€
156.0340	150,0	5,0	10,0	-	70	3,90
156.0342	150,0	6,0	12,0	-	120	3,90
156.0344	210,0	7,0	14,0	-	170	4,90
156.0346	215,0	8,0	16,0	-	230	6,90
156.0348	220,0	9,0	18,0	-	310	7,90
156.0350	220,0	10,0	20,0	-	410	9,90
156.0352	220,0	11,0	22,0	-	510	10,90
156.0354	250,0	12,0	24,0	-	640	12,90

CENTRE PUNCHES

Centre punch

- DIN 7250
- 8-point
- Tip can be re-sharpened
- Quenched and tempered
- Shaft with gold coated lacquer
- Highly polished
- Chrome molybdenum

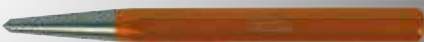

	L mm	D mm	S mm	Handle number	g	€
162.0361	120,0	4,0	10,0	-	65	2,90
162.0362	120,0	5,0	12,0	-	90	2,90
162.0363	150,0	5,0	12,0	-	120	2,90
162.0364	150,0	6,0	14,0	-	200	9,90
162.0365	150,0	8,0	18,0	-	260	5,90

Centre punch

- Round
- Quenched and tempered
- Burnished
- Chrome vanadium



	L mm	D mm	S mm	Handle number	g	€
156.0404	100,0	4,0	10,0	-	30	1,50
156.0406	115,0	6,0	10,0	-	60	1,90
156.0408	120,0	8,0	12,0	-	120	1,90
156.0410	130,0	10,0	14,0	-	135	2,50



Centre punch

- 8-point
- Quenched and tempered
- Mirror polished
- Highly polished
- Chrome vanadium



	L mm	D mm	S mm	Handle number	g	€
156.0175	120,0	5,0	10,0	-	60	1,90

Centre punch with hand grip

- 8-point
- Quenched and tempered
- Tip can be re-sharpened
- Highly polished
- Chrome molybdenum



	L mm	D mm	S mm	g	€
156.0243	185,0	10,0	10,0	118	7,90

Automatic centre punch

- Round
- Ergonomic handle
- Power of impact 17-20 kg
- Phosphate finish
- Chrome vanadium

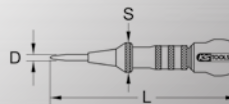

	L mm	D mm	S mm	g	€
156.0466	160,0	4,0	25,0	250	24,90

SCRIBER

Scriber

- For marking of work pieces
- Straight and 70° bent tip
- Knurled handle
- Hardened point
- Burnished
- Special tool steel



	L mm	D mm	g	€
300.0300	190,0	4,0	10	1,90

Hard metal scriber

- For marking of work pieces
- Straight and 70° bent tip
- With hard metal tip
- Hardened point
- Special tool steel

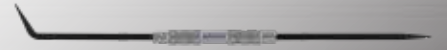

	L mm	D mm	g	€
300.2136	250,0	8,0	46	3,90

Hard metal scriber

- For marking of work pieces
- Straight and one-sided tip
- With hard metal tip
- Hardened point
- Special tool steel

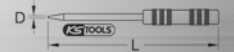

	L mm	D mm	g	€
300.2135	170,0	4,0	38	3,90

Hard metal scriber

- For marking of work pieces
- Straight form
- With hard metal tip
- Pocket clip
- Hardened point
- Chrome plated
- Special tool steel

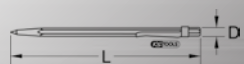

	L mm	D mm	g	€
300.0301	145,0	5,0	60	2,90
300.2137	150,0	6,0	36	4,90

Hard metal scriber in ball-point pen form

- For marking of work pieces
- Straight form
- Hardened and interchangeable hard metal tips
- Pocket clip
- Protection through foldaway needle tip
- Adjustable and lead bow mine
- Metal housing

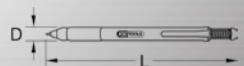

	L mm	D mm	Replacement tip	g	€
300.0302	150,0	8,0	300.0303	40	11,90

Hard metal scriber in ball-point pen form

- For marking of work pieces
- Straight form
- Hardened and interchangeable hard metal tips
- Pocket clip
- Protection through foldaway needle tip
- Adjustable and lead bow mine
- Metal housing

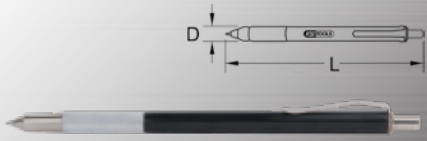

	L mm	D mm	Replacement tip	g	€
300.2138	160,0	8,0	300.2139	22	14,90

PUNCHES

Punches

- Impact cap on the handle end
- Sealed beech wood handle
- Mirror polished
- Highly polished
- Chrome vanadium

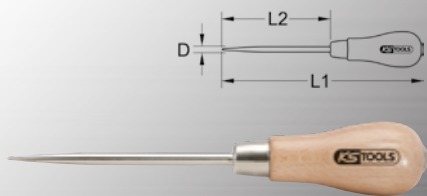

	L1 mm	L2 mm	D mm	g	€
300.1081	190,0	100,0	6,0	70	5,90

AWLE

Awle

- Impact cap on the handle end
- Sealed beech wood handle
- Mirror polished
- Highly polished
- Chrome vanadium

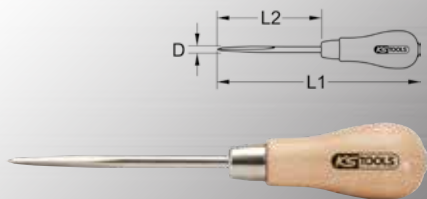

	L1 mm	L2 mm	D mm	g	€
300.1082	190,0	100,0	6,0	70	5,90



STAMP SETS

Number stamping set

- Lettering to DIN 1451
- Numbers „0 - 9“
- For stamping in materials up to 100 kp / mm² resistance
- 4 point shaft
- Font size 5 - 6mm
- Shaft engraved
- In plastic storage box



	g	€
156.0467 9 pcs Number stamping set	500	10,90

Letter stamping set

- Lettering to DIN 1451
- Letters „A - Z“
- For stamping in materials up to 100 kp / mm² resistance
- 4 point shaft
- Font size 5 - 6mm
- Shaft engraved
- In plastic storage box



	g	€
156.0468 27 pcs Letter stamping set	1,33	29,90

Universal letter and number punch set

- Lettering to DIN 1451
- For stamping in materials up to 100 kp / mm² resistance
- 4 point shaft
- Font size 5 - 6mm
- Shaft engraved
- In durable plastic storage case



	g	€
156.0465 40 pcs Universal letter and number punch set	2,37	179,90

1 x		
1 x		0 - 9
1 x		A - Z
1 x		
1 x		

GASKET RING DISMANTLING TOOL

Hook, 90° short, 180° short

- Ideal for removing and use of O rings and seals
- Special tool steel

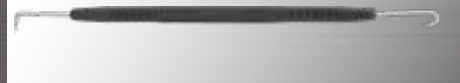

	g	€
550.1041 Hook, 90° short, 180° short	11	3,50

Hook, 45° long, 90° long

- Ideal for removing and use of O rings and seals
- Special tool steel



	g	€
550.1042 Hook, 45° long, 90° long	11	2,90

Hook tool set

- Ideal for removing and use of O rings and seals
- Special tool steel



	g	€
550.1040 2 pcs Hook tool set	30	7,90

consists of:

	g	€
550.1041 Hook, 90° short, 180° short bent	11	
550.1042 Hook, 45° long, 90° long	11	

Magnet and hook tool set

- Ideal for removing and use of O rings and seals
- With telescopic magnet attachment and replaceable hook
- Storage compartment in the handle for the various attachments
- Special tool steel



	g	€
550.1080 6 pcs Magnet and hook tool set	70	19,90

1 x		
1 x		
1 x		
1 x		
1 x		
1 x		

consists of:

		
550.1081	Basic unit	35
550.1082	Telescopic magnet attachment, 90-390 mm	13
550.1083	Hook attachment, straight, 75 mm	5
550.1084	Hook attachment, 90°, 75 mm	5
550.1085	Hook attachment, 120°, 75 mm	5
550.1086	Hook attachment, lateral bend, 75 mm	5

T hook, S form small

- Ideal for removing and use of O rings and seals
- Special tool steel



	Length mm		€
550.1074	120,0	42	8,90

T hook, S form large

- Ideal for removing and use of O rings and seals
- Special tool steel



	Length mm		€
550.1075	165,0	96	9,90

Hook, straight

- Ideal for removing and use of O rings and seals
- Two component handle
- Special tool steel



	Length mm		€
550.1046	140,0	27	2,90

Hook, 45°

- Ideal for removing and use of O rings and seals
- Two component handle
- Special tool steel



	Length mm		€
550.1047	140,0	27	2,90

Hook, 90°

- Ideal for removing and use of O rings and seals
- Two component handle
- Special tool steel



	Length mm		€
550.1048	140,0	27	2,90

Hook, 135°

- Ideal for removing and use of O rings and seals
- Two component handle
- Special tool steel



	Length mm		€
550.1049	140,0	27	3,90

Hook, straight

- Ideal for removing and use of O rings and seals
- Special tool steel



	Length mm		€
550.1071	215,0	91	5,90

Hook, 90°

- Ideal for removing and use of O rings and seals
- Special tool steel



	Length mm		€
550.1072	240,0	105	5,90

Hook, sickle

- Ideal for removing and use of O rings and seals
- Special tool steel





	Length mm		€
550.1073	185,0	88	5,90

Gasket ring dismantling tool

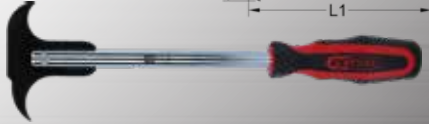
- sickle-shaped
- For the removal of washers
- Long durability through hardened leverage
- Universal usage
- Two component handle
- Burnished
- Chrome vanadium

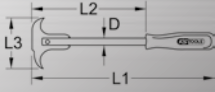



	L1 mm	L2 mm	L3 mm	D mm		€
550.1060	300,0	195,0	85,0	12,0	380	18,90

Hook tool set

- Ideal for removing and use of O rings and seals
- Two component handle
- Special tool steel



			€
550.1045	4 pcs Hook tool set	120	9,90

consists of:

		
550.1046	Hook, straight	27
550.1047	Hook, 45° offset	27
550.1048	Hook, 90° offset	27
550.1049	Hook, 135° bent	27



Master hook tool set

- Ideal for removing and use of O rings and seals
- Special tool steel



Art. No.	Quantity	Description	Weight (kg)	Price (€)
550.1070	9 pcs	Master hook tool set	680	19,90

consists of:

Art. No.	Description	Quantity
550.1046	Hook, straight	27
550.1047	Hook, 45° offset	27
550.1048	Hook, 90° offset	27
550.1049	Hook, 135° bent	27
550.1071	Hook, large, straight	91
550.1072	Hook, large, 90° bent	105
550.1073	Hook, large, sickle	88
550.1074	T hook, S form small, 120mm	42
550.1075	T hook, S form large, 165mm	96

HANDLE PUNCH

Handle punch

- According to DIN 7200 form A
- Strong forged form
- Pipe polished ground
- For punching holes and production of washers and gasket rings
- Interior conical for removing the blank head
- Shaft machined
- Red lacquer
- Cutting edge hardened
- Special tool steel



Art. No.	L mm	D mm	D	kg	€
129.2002	100,0	2,0		0,04	5,90
129.2003	100,0	3,0		0,04	5,90
129.2004	105,0	4,0		0,04	5,90
129.2005	110,0	5,0		0,05	5,90
129.2006	110,0	6,0		0,05	5,90
129.2007	115,0	7,0		0,05	6,90
129.2008	120,0	8,0		0,07	6,90
129.2009	120,0	9,0		0,07	6,90
129.2010	130,0	10,0		0,07	7,90
129.2011	130,0	11,0		0,10	8,90
129.2012	130,0	12,0	15/32"	0,12	8,90
129.2013	140,0	13,0	1/2"	0,16	9,90
129.2014	140,0	14,0	9/16"	0,16	10,90
129.2015	140,0	15,0	19/32"	0,16	11,90
129.2016	145,0	16,0	5/8"	0,17	12,90
129.2017	145,0	17,0	21/32"	0,21	13,90

Art. No.	L mm	D mm	D	kg	€
129.2018	145,0	18,0	11/16"	0,21	14,90
129.2019	145,0	19,0	3/4"	0,21	14,90
129.2020	160,0	20,0	25/32"	0,29	17,90
129.2021	160,0	21,0	13/16"	0,29	18,90
129.2022	160,0	22,0	7/8"	0,30	19,90
129.2023	170,0	23,0	29/32"	0,33	21,90
129.2024	170,0	24,0	15/16"	0,34	23,90
129.2025	170,0	25,0	1"	0,36	25,90
129.2026	170,0	26,0	1.1/32"	0,36	27,90
129.2027	175,0	27,0	1.1/16"	0,45	29,90
129.2028	175,0	28,0	1.3/32"	0,46	31,90
129.2029	175,0	29,0	1.1/8"	0,46	33,90
129.2030	190,0	30,0	1.3/16"	0,56	35,90
129.2031	190,0	31,0		0,56	37,90
129.2032	192,0	32,0	1.1/4"	0,56	39,90
129.2033	195,0	33,0		0,64	41,90
129.2034	195,0	34,0	1.5/16"	0,65	43,90
129.2035	195,0	35,0	1.3/8"	0,66	45,90
129.2036	195,0	36,0		0,66	47,90
129.2037	205,0	37,0	1.7/16"	0,75	49,90
129.2038	205,0	38,0	1.1/2"	0,78	52,90
129.2039	205,0	39,0		0,80	55,90
129.2040	205,0	40,0	1.9/16"	0,81	58,90
129.2041	205,0	41,0	1.5/8"	0,82	66,90
129.2042	220,0	42,0		0,98	70,90
129.2043	220,0	43,0	1.11/16"	0,98	73,90
129.2044	220,0	44,0		0,98	78,90
129.2045	220,0	45,0	1.3/4"	1,00	82,90
129.2046	220,0	46,0	1.13/16"	1,10	86,90
129.2047	230,0	47,0	1.7/8"	1,16	91,90
129.2048	230,0	48,0		1,18	98,90
129.2049	230,0	49,0	1.15/16"	1,19	102,90
129.2050	230,0	50,0		1,20	108,90
129.2051	230,0	51,0	2"	1,20	115,90
129.2052	240,0	52,0		1,85	123,90
129.2053	240,0	53,0		1,85	132,90
129.2054	240,0	54,0	2.1/8"	1,85	138,90
129.2055	240,0	55,0		1,85	144,90
129.2056	260,0	56,0	2.3/16"	1,85	153,90
129.2057	260,0	57,0		1,85	159,90
129.2058	260,0	58,0	2.1/4"	1,85	166,90
129.2059	260,0	59,0		1,85	175,90
129.2060	260,0	60,0		1,85	182,90
129.2061	260,0	61,0		1,85	191,90
129.2062	260,0	62,0		1,85	201,90
129.2063	260,0	63,0		1,85	209,90
129.2064	260,0	64,0	2.1/2"	1,85	213,90
129.2065	260,0	65,0		3,65	222,90
129.2066	260,0	66,0		3,65	227,90
129.2067	300,0	67,0		3,65	231,90
129.2068	300,0	68,0		3,65	235,90
129.2069	300,0	69,0		3,65	237,90
129.2070	300,0	70,0	2.3/4"	3,65	242,90
129.2071	300,0	71,0		3,65	250,90
129.2072	300,0	72,0		3,65	255,90
129.2073	300,0	73,0		3,65	268,90
129.2074	300,0	74,0		3,65	277,90
129.2075	300,0	75,0		4,30	289,90
129.2076	300,0	76,0	3"	4,30	307,90
129.2077	340,0	77,0		4,30	312,90
129.2078	340,0	78,0		4,30	320,90
129.2079	340,0	79,0		4,30	328,90
129.2080	340,0	80,0		4,30	338,90
129.2085	340,0	85,0		4,30	380,90
129.2090	345,0	90,0		5,15	428,90
129.2095	345,0	95,0	3.3/4"	8,50	514,90
129.2100	380,0	100,0		8,50	553,90
129.2105	380,0	105,0		8,50	592,90
129.2110	380,0	110,0		8,50	634,90
129.2115	380,0	115,0	4.1/2"	8,50	634,90
129.2120	380,0	120,0		8,50	669,90



Arc punch set

- According to DIN 7200 form A
- Strong forged form
- Pipe polished ground
- For punching holes and production of washers and gasket rings
- Interior conical for removing the blank head
- Shaft machined
- Red lacquer
- Cutting edge hardened
- Special tool steel



Art. No.	Quantity	Description	Weight (kg)	Price (€)
129.2102	7 pcs	3 - 5 - 7 - 8 - 10 - 11 - 13 mm	0,72	56,90
129.2103	8 pcs	3 - 5 - 7 - 8 - 10 - 13 - 16 - 19 mm	1,00	77,90
129.2106	8 pcs	6 - 8 - 10 - 12 - 14 - 16 - 20 - 25 mm	1,51	102,90
129.2104	10 pcs	3 - 5 - 7 - 8 - 10 - 13 - 16 - 19 - 22 - 25 mm	1,00	124,90

ROUND HOLE PUNCH

Round hole punch

- According to DIN 7200 Form B
- Strong forged form
- Pipe polished ground
- For punching holes and production of washers and gasket rings
- Interior conical for removing the blank head
- Red lacquer
- Cutting edge hardened
- Special tool steel

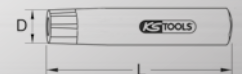

Art. No.	L mm	D mm	kg	€
129.2302	105,0	2,0	22	3,90
129.2303	105,0	3,0	28	3,90
129.2304	110,0	4,0	35	3,90
129.2305	115,0	5,0	47	3,90
129.2306	115,0	6,0	56	3,90
129.2307	120,0	7,0	56	3,90
129.2308	120,0	8,0	71	4,90
129.2309	125,0	9,0	71	4,90
129.2310	125,0	10,0	82	5,90
129.2311	125,0	11,0	110	6,90
129.2312	130,0	12,0	130	7,90
129.2313	130,0	13,0	140	8,90
129.2314	135,0	14,0	170	9,90
129.2315	135,0	15,0	180	10,90
129.2316	140,0	16,0	200	11,90
129.2317	140,0	17,0	220	13,90
129.2318	150,0	18,0	280	14,90
129.2319	150,0	19,0	300	17,90
129.2320	156,0	20,0	350	18,90
129.2321	156,0	21,0	380	20,90
129.2322	156,0	22,0	430	21,90
129.2323	156,0	23,0	460	24,90
129.2324	160,0	24,0	550	26,90
129.2325	160,0	25,0	580	27,90

Round hole punch set

- According to DIN 7200 Form B
- Strong forged form
- Pipe polished ground
- For punching holes and production of washers and gasket rings
- Interior conical for removing the blank head
- Shaft machined
- Red lacquer
- Cutting edge hardened
- Special tool steel



				g	€
129.2113	7 pcs	5 - 6 - 7 - 10 - 11 - 12 mm		620	36,90
129.2108	7 pcs	3 - 5 - 7 - 8 - 10 - 11 - 13 mm		730	41,90
129.2109	8 pcs	3 - 5 - 7 - 8 - 10 - 13 - 16 - 19 mm		1260	63,90
129.2107	9 pcs	2 - 3 - 4 - 5 - 6 - 7 - 8 - 9 - 10 mm		640	41,90
129.2111	9 pcs	3 - 5 - 7 - 8 - 10 - 13 - 16 - 19 - 22 mm		1760	86,90
129.2112	10 pcs	3 - 5 - 7 - 8 - 10 - 13 - 16 - 19 - 25 mm		2360	113,90

HOLE PUNCHES

Hole punch set

- For punching out rings and for making discs and holes
- Punches can also be used in pairs
- Chrome vanadium
- In durable plastic storage case

Suitable for: foam rubber, cardboard, leather, rubberfibrous materials, plastics and lead



		kg	€
129.0100	16 pcs Hole punch set	1,10	183,90

consists of:

		g
129.0101	Three-size holder for seal punches	300
129.0103	Hole punch, thread holder, 3mm	10
129.0104	Hole punch, thread holder, 4mm	10
129.0106	Hole punch, thread holder, 6mm	10
129.0108	Hole punch, thread holder, 8mm	10
129.0110	Hole punch, thread holder, 10mm	10
129.0112	Hole punch, punching iron mandrel, 12mm	20
129.0114	Hole punch, punching iron mandrel, 14mm	20
129.0116	Hole punch, punching iron mandrel, 16mm	20
129.0118	Hole punch, punching iron mandrel, 18mm	20
129.0120	Hole punch, punching iron mandrel, 20mm	20
129.0122	Hole punch, punching iron mandrel, 22mm	40
129.0124	Hole punch, punching iron mandrel, 24mm	40
129.0126	Hole punch, punching iron mandrel, 26mm	40
129.0128	Hole punch, punching iron mandrel, 28mm	40
129.0130	Hole punch, punching iron mandrel, 30mm	40

RIVET PROCESSING TOOL

Rivet setters

- Working ends polished ground and clear lacquered
- Suitable for rivets according to DIN 660 / 661 / 662 / 674
- Chrome vanadium



	Ø rivet mm	L mm	S mm	g	€
129.2400	2,0	100,0	10,0	60	6,90
129.2401	3,0	100,0	10,0	60	6,90
129.2402	4,0	100,0	12,0	90	6,90
129.2403	5,0	110,0	14,0	135	7,90
129.2404	6,0	110,0	14,0	135	8,90
129.2405	7,0	120,0	16,0	190	10,90
129.2406	8,0	120,0	16,0	190	10,90
129.2407	9,0	130,0	18,0	265	11,90
129.2408	10,0	130,0	20,0	325	13,90

Rivet setter set

- According to DIN 7200 Form B
- Suitable for rivets according to DIN 660 / 661 / 662 / 674
- Strong forged form
- Pipe polished ground
- For punching holes and production of washers and gasket rings
- Interior conical for removing the blank head
- Shaft machined
- Red lacquer
- Cutting edge hardened
- Special tool steel
- In plastic support bracket



		g	€
129.2420	5 pcs 2 - 3 - 4 - 5 - 6 mm	520	35,90

Rivet setter and rivet header, combined

- 8-point
- Premium tempered and hardened steel
- Lacquered
- Chrome vanadium

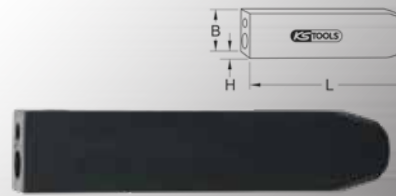

	Ø rivet mm	L mm	B mm	H mm	g	€
129.2210	2,0	100,0	16,0	10,0	115	19,90
129.2211	3,0	100,0	16,0	10,0	115	19,90
129.2212	4,0	100,0	20,0	10,0	145	19,90
129.2213	5,0	110,0	25,0	12,0	215	20,90
129.2214	6,0	120,0	25,0	15,0	310	20,90
129.2215	7,0	120,0	30,0	15,0	330	27,90
129.2216	8,0	140,0	40,0	20,0	680	27,90
129.2217	9,0	160,0	40,0	25,0	950	36,90
129.2218	10,0	160,0	40,0	25,0	940	36,90

RIVET SETS

Rivet head setter

- Working ends polished ground and clear lacquered
- Suitable for rivets according to DIN 660
- Chrome vanadium

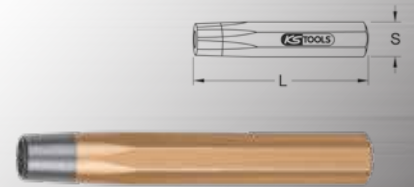

	Ø rivet mm	L mm	S mm	g	€
129.2199	2,0	100,0	10,0	60	5,90
129.2200	3,0	100,0	10,0	60	5,90
129.2201	4,0	100,0	12,0	90	6,90
129.2202	5,0	110,0	14,0	135	7,90
129.2203	6,0	110,0	16,0	175	8,90
129.2204	7,0	120,0	18,0	240	9,90
129.2205	8,0	120,0	20,0	305	11,90
129.2206	9,0	130,0	22,0	400	14,90
129.2207	10,0	130,0	24,0	480	14,90

Rivet head setter set

- Working ends polished ground and clear lacquered
- Suitable for rivets according to DIN 660
- Chrome vanadium
- In plastic support bracket



		g	€
129.2209	5 pcs 2 - 3 - 4 - 5 - 6 mm	520	37,90

FLATTENERS

Tapware assembly and dismantling set

- 8-point
- Quenched and tempered
- Special tool steel



	L mm	S mm	g	€
156.0770	170,0	16,0	510	22,90

TAPER PUNCHES

Punch drawbore pin

- Hardened through the whole length
- Cone polished
- Carbon manganese silicon steel

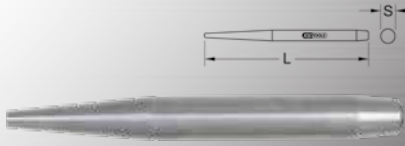

	L mm	S mm	kg	€
129.2161	110,0	11,0	0,07	6,90
129.2162	120,0	13,0	0,11	8,90
129.2163	150,0	15,0	0,19	10,90
129.2164	170,0	17,0	0,27	11,90
129.2165	170,0	19,0	0,34	13,90
129.2166	190,0	21,0	0,45	16,90
129.2167	200,0	23,0	0,47	19,90
129.2168	200,0	25,0	0,68	22,90
129.2169	210,0	27,0	0,84	22,90
129.2170	210,0	28,0	0,91	27,90
129.2171	230,0	29,0	1,06	28,90
129.2172	230,0	31,0	1,21	31,90
129.2173	250,0	33,0	1,52	33,90
129.2174	280,0	34,0	1,80	34,90
129.2175	280,0	36,0	2,02	37,90
129.2176	280,0	37,0	2,14	41,90

Assembly drawbore pin

- Hardened through the whole length
- Cone polished
- Carbon manganese silicon steel

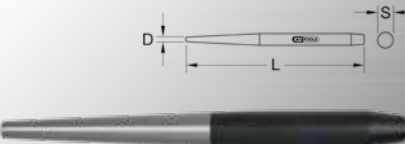

	L mm	D mm	S mm	kg	€
129.2177	120,0	5,0	11,0	75	7,90
129.2178	120,0	5,0	13,0	90	8,90
129.2179	150,0	6,0	15,0	165	10,90
129.2180	170,0	7,0	17,0	240	12,90
129.2181	170,0	7,0	19,0	300	13,90
129.2182	190,0	8,0	21,0	410	14,90
129.2183	190,0	9,0	23,0	485	19,90
129.2184	200,0	10,0	25,0	585	22,90
129.2185	210,0	12,0	28,0	805	22,90
129.2186	230,0	12,0	31,0	1050	27,90
129.2187	250,0	13,0	34,0	1345	31,90
129.2188	270,0	14,0	37,0	1720	35,90

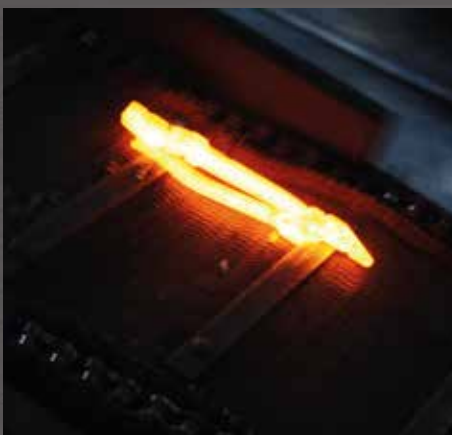

Assembly punch

- Hardened through the whole length
- Cone polished
- Chrome vanadium

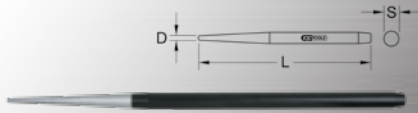

	L mm	D mm	S mm	kg	€
129.2189	180,0	5,0	12,0	110	16,90
129.2190	200,0	6,0	13,0	150	17,90
129.2191	200,0	8,0	16,0	220	21,90
129.2192	200,0	9,0	20,0	340	27,90
129.2193	230,0	10,0	22,0	460	32,90
129.2194	250,0	11,0	24,0	620	36,90
129.2195	280,0	12,0	27,0	870	40,90
129.2196	315,0	14,0	30,0	1260	47,90
129.2197	340,0	15,0	32,0	1570	68,90
129.2198	380,0	16,0	36,0	2230	84,90

BENDING IRONS AND PRY BARS

Pry bar

- Round
- Quenched and tempered
- Forged
- Cone polished
- Special tool steel

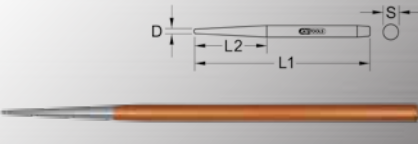

	D mm	L1 mm	L2 mm	S mm	kg	€
129.2220	5,5	500,0	170,0	20,0	970	52,90

Bending iron/pry bar

- 4 point
- Quenched and tempered
- Forged
- Cone polished
- Special tool steel

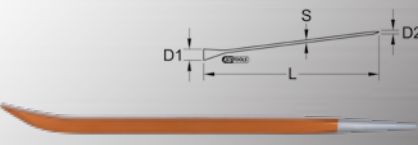

	D1 mm	D2 mm	L mm	S mm	kg	€
129.2221	14,0	1,0	400,0	14,0	500	43,90

Bending iron/pry bar

- Round
- Quenched and tempered
- Forged
- Special tool steel

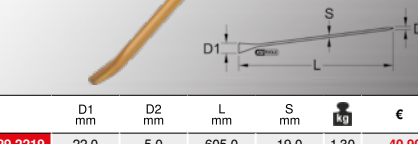

	D1 mm	D2 mm	L mm	S mm	kg	€
129.2219	22,0	5,0	605,0	19,0	1,30	40,90

Bending iron/pry bar

- 6 point
- Quenched and tempered
- Forged
- Cone polished
- Special tool steel

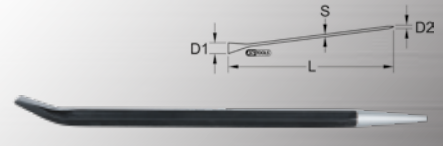

	D1 mm	D2 mm	L mm	S mm	kg	€
129.2222	22,0	5,0	405,0	16,0	650	48,90

Pry bar

- Best suited for and breakdown and installation work
- For pressure testing securely-fitted parts
- Ergonomic single component handle
- Hardened through the whole length
- Chrome molybdenum

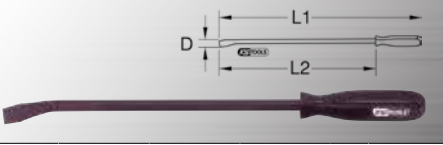

	D mm	L1 mm	L2 mm	kg	€
911.8101	11,0	200,0	105,0	76	2,90
911.8102	16,0	300,0	195,0	200	3,90
911.8103	20,0	450,0	315,0	397	5,90
911.8104	20,0	600,0	465,0	507	8,90

Pry bar sets

- Best suited for and breakdown and installation work
- For pressure testing securely-fitted parts
- Ergonomic single component handle
- Hardened through the whole length
- Chrome molybdenum



	kg	€		
911.8100	4 pcs	11 x 200 mm - 16 x 300 mm - 20 x 450 mm - 20 x 600 mm	1,33	19,90





Flexible roll head pry bar

- Extremely versatile and robust execution
- Variable adjustable roll head
- Maximum power transmission in the narrowest area
- Optimal leverage in minimal work area
- Special tool steel



	Length mm	Assembly levels		€
911.8176	250,0	5	385	33,90
911.8177	300,0	5	455	38,90
911.8178	400,0	5	565	51,90

Flexible roll head pry bar set

- Extremely versatile and robust execution
- Variable adjustable roll head
- Maximum power transmission in the narrowest area
- Optimal leverage in minimal work area
- Special tool steel



			€
911.8175	3 pcs Flexible roll head pry bar set	1,50	108,90

consists of:

			€
911.8176	Flexible roll head pry bar, 250 mm	385	
911.8177	Flexible roll head pry bar, 300 mm	455	
911.8178	Flexible roll head pry bar, 400 mm	565	

Pry bar

- Angular lever end guarantees non slip surface
- Ideally suited for and breakdown and installation work
- Go through blade and hammer cap
- Suitable for the testing of defective bearings
- Two component handle
- Special tool steel
- In durable plastic storage case



	Bend radius	Length mm		€
911.8411	0°	900,0	1,70	56,90
911.8412	45°	900,0	1,75	56,90
911.8413	75°	600,0	1,17	56,90
911.8414	90°	600,0	1,20	56,90

Pry bar

- Angular lever end guarantees non slip surface
- Ideally suited for and breakdown and installation work
- Go through blade and hammer cap
- Suitable for the testing of defective bearings
- Two component handle
- Special tool steel
- In durable plastic storage case



	Bend radius	Length mm		€
911.8415	45°	1150,0	4,75	271,90

Pry bar sets

- Angular lever end guarantees non slip surface
- Ideally suited for and breakdown and installation work
- Go through blade and hammer cap
- Suitable for the testing of defective bearings
- Two component handle
- Special tool steel
- In durable plastic storage case



			€
911.8410	4 pcs Pry bar sets	8,70	179,90

consists of:

			€
911.8411	Pry bar, 0°, 900mm	1,70	
911.8412	Pry bar, 45°, 900mm	1,75	
911.8413	Pry bar, 75°, 600mm	1,17	
911.8414	Pry bar, 90°, 600mm	1,20	
911.8415	Pry bar, 45°, 1150mm	4,75	

Telescopic flexible roll head pry bar

- Lever extension with push-button in steps
- Roller head adjustable in steps
- Extra narrow, with recessed push button
- Maximum power transmission in the narrowest area
- Optimal leverage in minimal work area
- Special tool steel



	L mm	H mm	B mm		€
911.8186	325-460	90,0	12,0	780	64,90
911.8187	600-915	120,0	20,0	1900	89,90
911.8188	865-1350	145,0	24,0	4260	187,90



156.0180**Pin punch set**

- 8-point
- Quenched and tempered
- Mirror polished
- Highly polished
- In metal stand with the possibility of wall hanging



5 x Punches, conical:
2 - 3 - 4 - 5 - 6 mm

6 x Punches, cylindrical:
2 - 3 - 4 - 5 - 6 - 8 mm

6 x Punches, extra long:
3 - 4 - 5 - 6 - 8 - 10 mm

66,90 €

17

pcs

162.0370**Pin punch set**

- Quenched and tempered
- Tip can be re-sharpened
- Shaft with gold coated lacquer
- Chrome molybdenum
- In metal storage box



150x10x3 -
150x10x4 -
150x10x5 -
150x10x6 -
150x12x8 -
150x12x10mm

31,90 €

6

pcs

911.8175**Flexible roll head pry bar**

- Extremely versatile and robust execution
- Variable adjustable roll head
- Maximum power transmission in the narrowest area
- Optimal leverage in minimal work area
- Special tool steel



108,90 €

3

pcs

Your Local Distributor:

PREMIUM-WERKZEUGE

KS TOOLS
PREMIUM TOOLS

KS Tools Werkzeuge - Maschinen GmbH
Seligenstädter Grund 10 - 12
D-63150 Heusenstamm

GERMANY

Tel.: +49(0) 61 04 49 74-0
Fax: +49(0) 61 04 49 74-11
e-mail: kstools@kstools.de
www.kstools.com

